

FUJI IGBT-IPM APPLICATION MANUAL

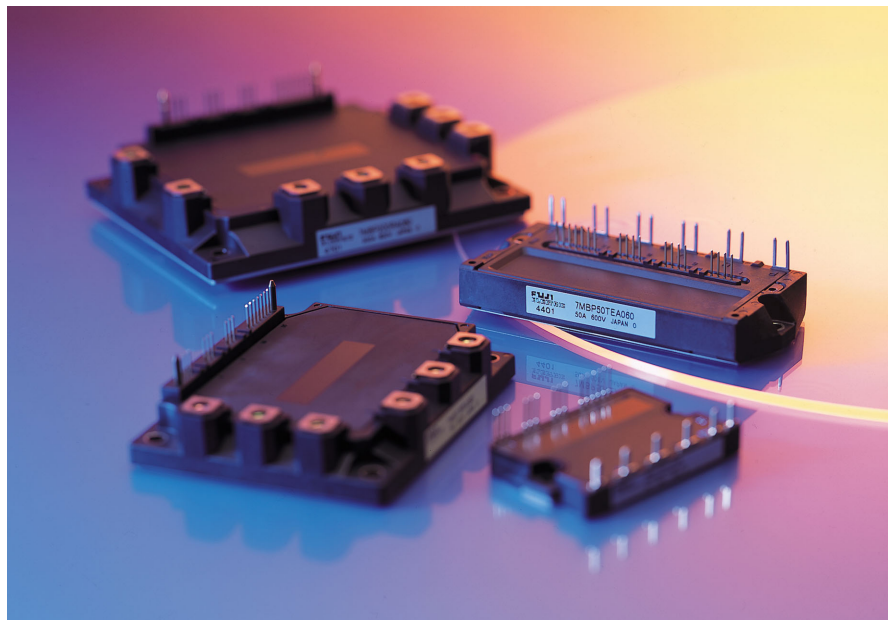

Fuji Electric Device Technology Co., Ltd.

CONTENTS

Chapter 1 Features

1. GBT-IPMs Characteristics	1-2
2. IPM Characteristics by Series	1-4
3. Definition of Type Name and Lot No.....	1-6
4. Lineup	1-7
5. Outline Drawings.....	1-8

Chapter 2 Description of Terminal Symbols and Terminology

1. Description of Terminal Symbols	2-2
2. Description of Terminology	2-3

Chapter 3 Description of Functions

1. Function Tables	3-2
2. Function Descriptions.....	3-4
3. Truth Tables.....	3-11
4. IPM Block Diagrams.....	3-13
5. Timing Charts	3-21

Chapter 4 Examples of Application Circuits

1. Examples of Application Circuits	4-2
2. Precautions	4-7
3. Photocoupler and Peripheral Circuits	4-10
4. Connectors.....	4-11

Chapter 5 Cooling Design

1. Cooler (Heat Sink) Selection Method	5-2
2. Notes on Heat Sink Selection.....	5-2

Chapter 6 Cautions on Use

1. Main Power Source.....	6-2
2. Control Power Source	6-3
3. Protection Functions.....	6-4
4. Power Cycling Capability.....	6-6
5. Other	6-6

Chapter 7 Trouble Shooting

1. Trouble Shooting	7-2
2. Fault Analysis Diagrams.....	7-2
3. Alarm Cause Analysis Diagram	7-8

Chapter 1

Features

Contents	Page
1 GBT-IPMs Characteristics	1-2
2 IPM Characteristics by Series	1-4
3 Definition of Type Name and Lot No.....	1-6
4 Lineup.....	1-7
5 Outline Drawings	1-8

1 GBT-IPMs Characteristics

An intelligent power module (IPM) has the following characteristics when compared with a combination of IGBT modules and drive circuits.

1.1 Built-in drive circuit

- IGBT gate drives operate under optimal conditions.
- Since the wiring length between the internal drive circuit and IGBT is short and the impedance of the drive circuit is low, no reverse bias DC source is required.
- The R-series IPM (R-IPM) devices require four control power sources, one source on the lower arm side, and three individual sources on the upper arm side with proper circuit isolation.

1.2 Built-in protection circuits

- The following built-in protection circuits are included in the R-IPM devices:
 - (OC): Overcurrent protection
 - (SC): Short-circuit protection
 - (UV): Undervoltage protection for control power source
 - (OH): Overheating protection
 - (ALM): External alarm output
- The OC and SC protection circuits provide protection against IGBT damage caused by overcurrent or load short-circuits. These circuits monitor the collector current using detection elements incorporated in each IGBT and thus can minimize the possibility of severe damage to the IGBT. They also protect against arm short-circuits.^{*1}
- The UV protection circuit is in all of the IGBT drive circuits. This circuit monitors the Vcc supply voltage level against the IGBT drive Vin.
- The OH protection circuit protects the IGBT and FWD from overheating. It also monitors the insulating substrate's temperature with temperature detection elements installed on the insulating substrates inside the IPM.
(Case temperature overheating protection: TcOH)^{*2}

- Additionally, each IGBT chip contains a temperature detection element on the IGBT die, which allows the OH to act rapidly when abnormally high chip temperatures are detected. (Junction temperature overheating protection: TjOH)
- The ALM circuit outputs an alarm signal to outside of the IPM, making it possible to shutdown the system reliably by outputting the alarm signal to the microcontroller which controls IPM when the circuit detects an abnormal condition (specified above).^{*2}

^{*1} The N-line shunt resistance method is used for overcurrent detection of small-capacity types.

^{*2} Refer to Chapter 3 “Description of Functions” for the protective functions of each IPM.

1.3 Built-in brake circuit (7 in 1 IPM)

- For a motor control inverter application, a brake circuit can be built to protect bus overvoltage by just adding a power dissipating resistor.
- The drive circuits and protection circuits are included in the brake IGBT in the same way as inverter IGBTs.

2 IPM Characteristics by Series

2.1 R-IPM, R-IPM3 series

2.1.1 Small-capacity types

A lineup of small-capacity types with 15 to 30 A for 600 V systems and 15 A for 1200 V systems is available. (P617, P619 package)

- P617 package products are a type without a copper base, while P619 package products are a type with a copper base, which further improves the heat radiation ability.
- The control input terminals have a standard pitch of 2.54 mm.
- The shape of the main terminals is the Faston shape, and as the height is the same as that of the control input terminals, connection by the same printed boards is possible with the soldering method as well as with the connector method.
- By improvement of the trade-off between $V_{ce(sat)}$ and switching loss, the total loss has been improved.
- The chip is protected from abnormal heating by IGBT chip overheating protection.

2.1.2 Medium-capacity types (alarm output only for the lower arm)

A lineup of medium-capacity types with 50 to 150 A for 600 V systems and 25 to 75 A for 1200 V systems is available. (P610, P611 package)

- The control input terminals have a standard pitch of 2.54 mm, they are arranged in one line, and connection is possible with one connector for general use. A guide pin makes insertion of the connector for the printed board easy.
- The main power source inputs (P, N), the brake output (B), and the output terminals (U, V, W) are arranged close to each other, and the main wiring is a simple package construction.
- As the main terminals are M5 screws, large currents can be connected securely.
- The screw diameter for connection to the heat sink is M5, the same as for the main terminals.
- As all electrical connections are made by screws or connectors, soldering is not required and removal is easy.
- By improvement of the trade-off between $V_{ce(sat)}$ and switching loss, the total loss has been improved.
- The chip is protected from abnormal heating by IGBT chip overheating protection.^{*3}

^{*3}There is no alarm output from the upper arm side.

2.1.3 Medium-capacity types (with upper arm alarm output function)

A lineup of medium-capacity types with 50 to 150 A for 600 V systems and 25 to 75 A for 1200 V systems is available. (P621 package)

- OC, SC, UV, and TjOH alarm signals can be output from the upper arm. This allows secure protection against trouble from ground faults, etc.^{*4}
- As the main terminals are M5 screws, large currents can be connected securely.
- The screw diameter for connection to the heat sink is M5, the same as for the main terminals.

- As all electrical connections are made by screws or connectors, soldering is not required and removal is easy.
- By improvement of the trade-off between $V_{ce(sat)}$ and switching loss, the total loss has been improved.
- The chip is protected from abnormal heating by IGBT chip overheating protection.
^{*4} The TcOH alarm is output only from the lower arm.

2.1.4 Large-capacity types (alarm output only for the lower arm)

A lineup of large-capacity types with 200 to 300 A for 600 V systems and 100 to 150 A for 1200 V systems is available. (P612 package)

- The layout of the control input terminals is the same as for the medium-capacity standard package, and correspondence is possible with one connector type.
- The main power source inputs (P, N), the brake output (B), and the output terminals (U, V, W) are arranged close to each other, and the main wiring is a simple package construction.
- As the main terminals are M5 screws, large currents can be connected securely.
- The screw diameter for connection to the heat sink is M5, the same as for the main terminals.
- As all electrical connections are made by screws or connectors, soldering is not required and removal is easy.
- By improvement of the trade-off between $V_{ce(sat)}$ and switching loss, the total loss has been improved.
- The chip is protected from abnormal heating by IGBT chip overheating protection.^{*5}

^{*5} There is no alarm output from the upper arm side.

2.2 Econo IPM series

The Econo IPM series is a lineup with 50 to 150 A for 600 V systems and 25 to 75 A for 1200 V systems. (P622 package)

- In comparison with the medium-capacity types, the mounting area has been reduced by approximately 30% and the mass has been reduced by approximately 40%, contributing to reduction of the device size.
- As the height is the same as that of Econo DIMs (Econo Diode Modules), connection is possible with the same printed circuit boards.
- OC, SC, UV, and TjOH alarm signals can be output from the upper arm. This makes secure protection against trouble from ground faults etc. possible.
- The chip is protected from abnormal heating by IGBT chip overheating protection.

3 Definition of Type Name and Lot No.

• Type name

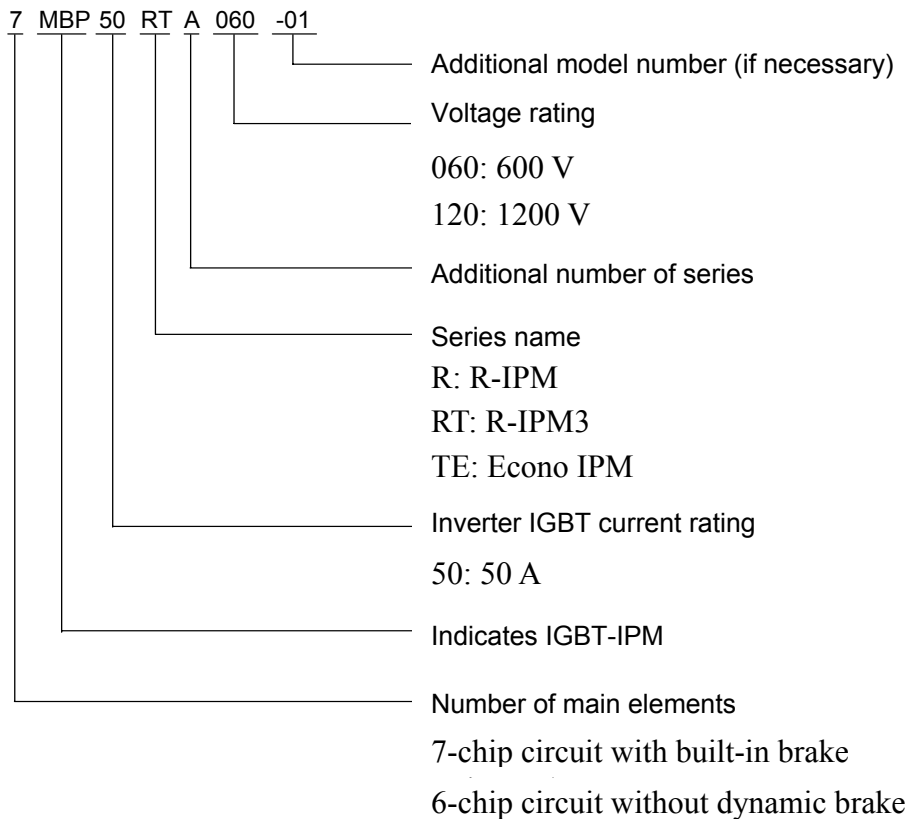

• Lot No.

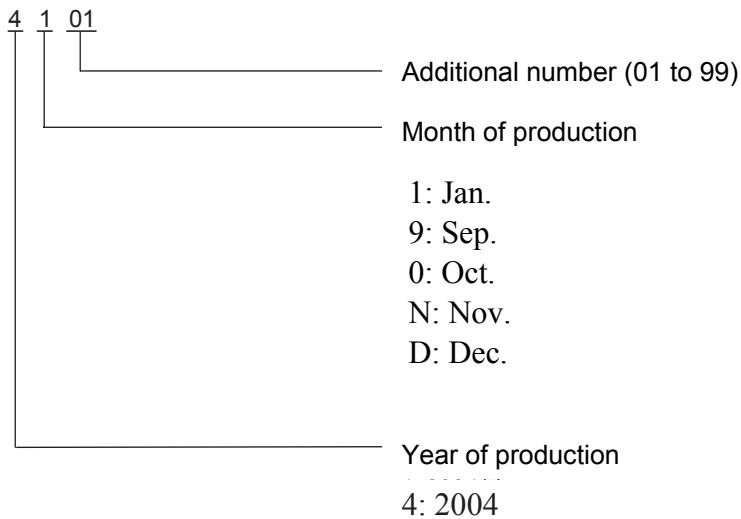

4 Lineup

600 V system, 15 to 75 A

	15A	20A	30A	50A	75A
R-IPM	6MBP15RH060	6MBP20RH060	6MBP30RH060	6MBP50RA060 7MBP50RA060	6MBP75RA060 7MBP75RA060
R-IPM3	–	6MBP20RTA060	–	6MBP50RTB060 7MBP50RTB060 6MBP50RTJ060 7MBP50RTJ060	6MBP75RTB060 7MBP75RTB060 6MBP75RTJ060 7MBP75RTJ060
Econo IPM	–	–	–	6MBP50TEA060 7MBP50TEA060	6MBP75TEA060 7MBP75TEA060

600 V system, 100 to 300 A

	100A	150A	200A	300A
R-IPM	6MBP100RA060 7MBP100RA060	6MBP150RA060 7MBP150RA060	6MBP200RA060 7MBP200RA060	6MBP300RA060 7MBP300RA060
R-IPM3	6MBP100RTB060 7MBP100RTB060 6MBP100RTJ060 7MBP100RTJ060	6MBP150RTB060 7MBP150RTB060 6MBP150RTJ060 7MBP150RTJ060	–	–
Econo IPM	6MBP100TEA060 7MBP100TEA060	6MBP150TEA060 7MBP150TEA060	–	–

1200 V system

	15A	25A	50A	75A	100A	150A
R-IPM	6MBP15RA120	6MBP25RA120 7MBP25RA120 6MBP25RJ120 7MBP25RJ120	6MBP50RA120 7MBP50RA120 6MBP50RJ120 7MBP50RJ120	6MBP75RA120 7MBP75RA120 6MBP75RJ120 7MBP75RJ120	6MBP100RA120 7MBP100RA120	6MBP150RA120 7MBP150RA120
Econo IPM	–	6MBP25TEA120 7MBP25TEA120	6MBP50TEA120 7 MBP50TEA120	6MBP75TEA120 7MBP75TEA120	–	–

5 Outline Drawings

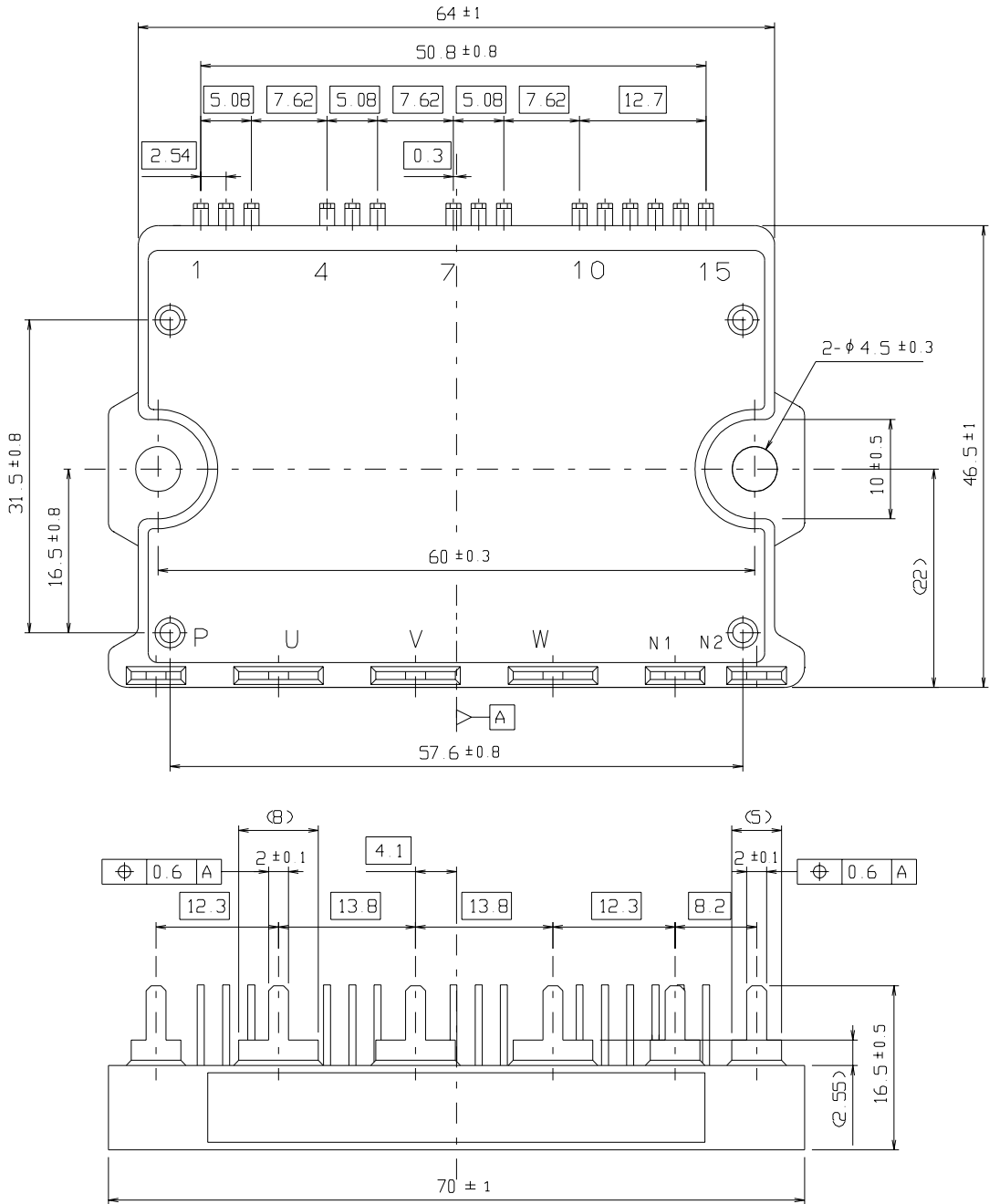

Fig. 1-1 Outline Drawing (P617)

Type name: 6MBP15RH060, 6MBP20RH060, 6MBP30RH060

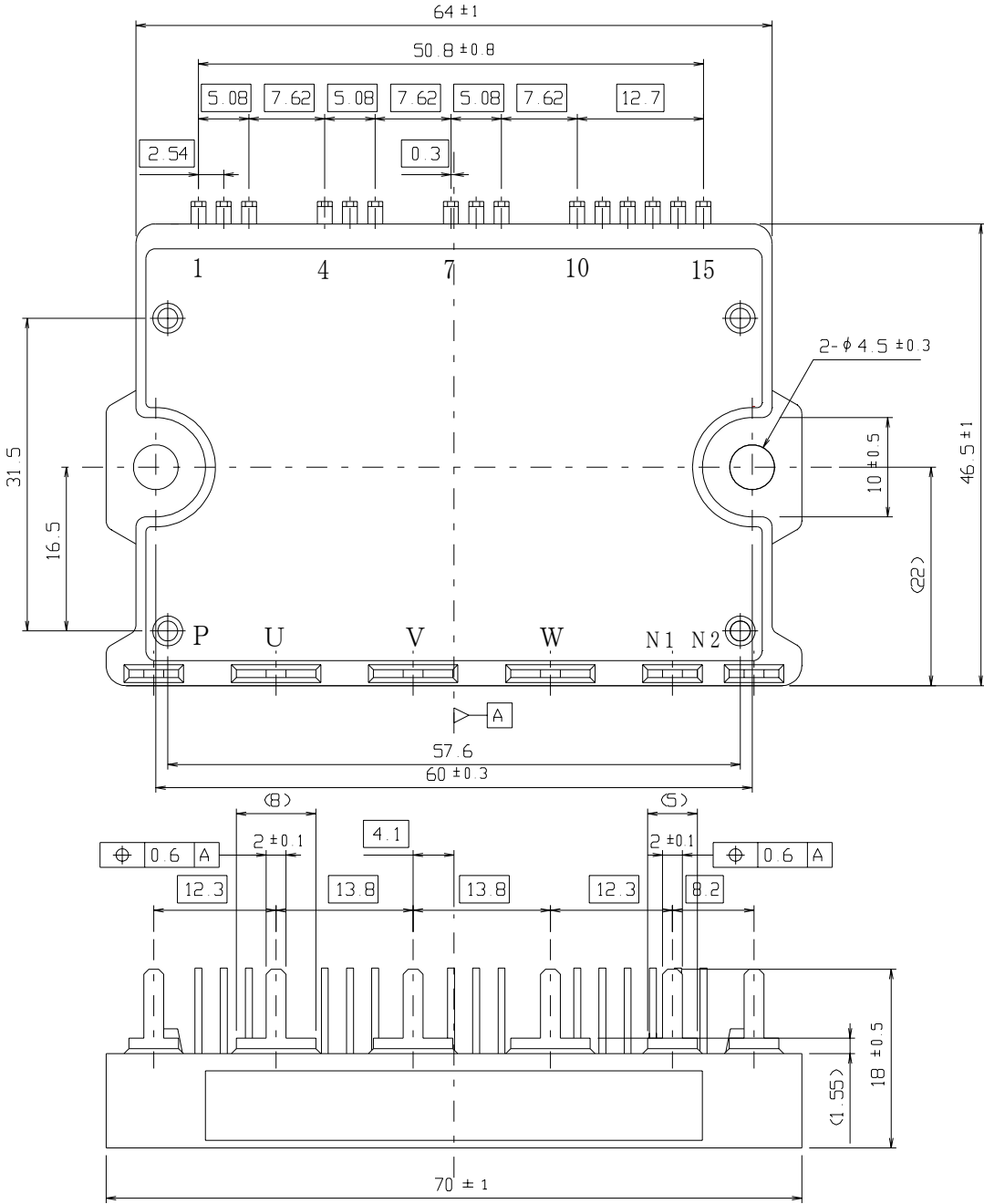

Fig. 1-2 Outline Drawing (P619)

Type name: 6MBP20RTA060, 6MBP15RA120

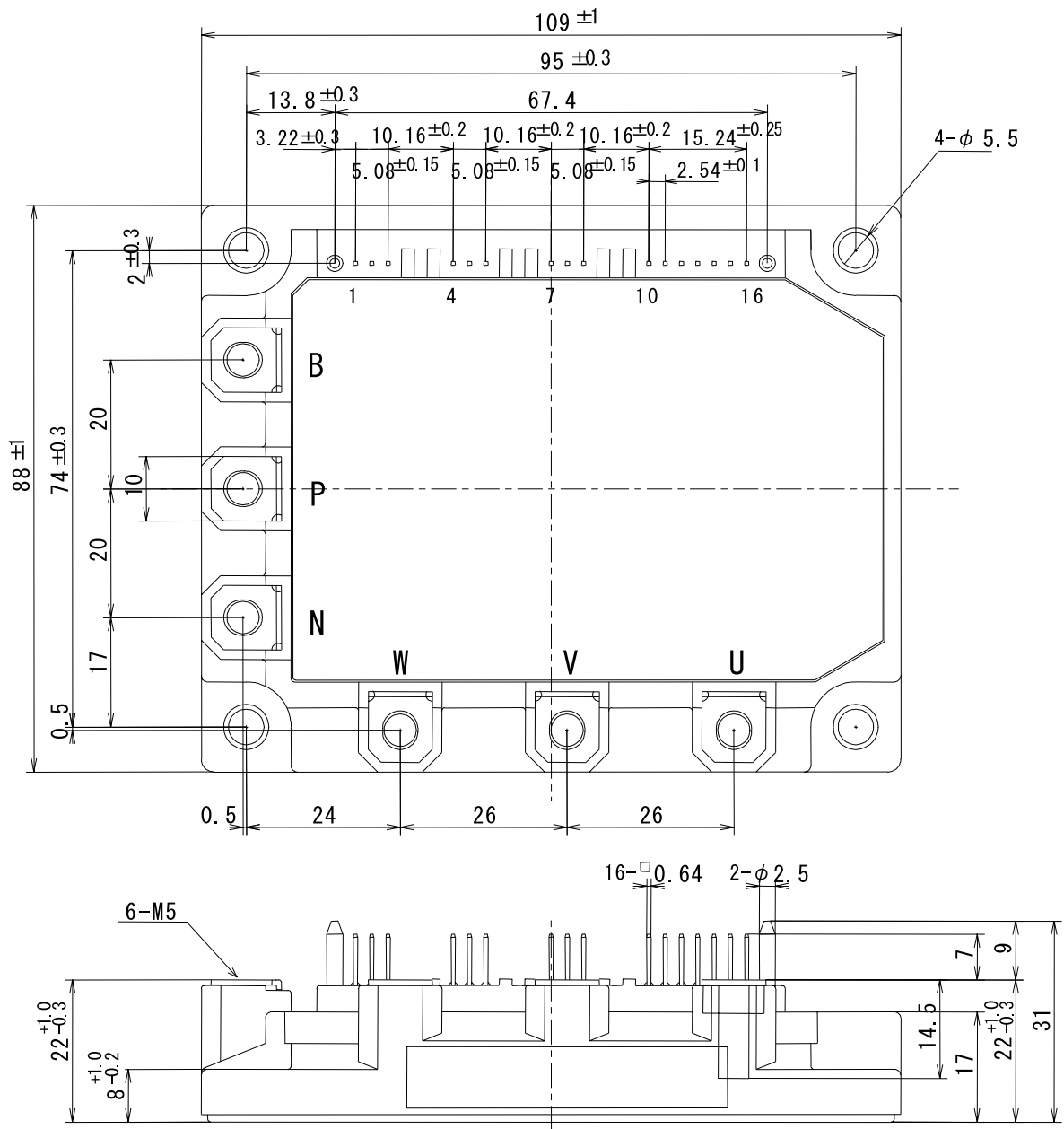

Fig. 1-3 Outline Drawing (P610)

Type name: 6MBP50RA060, 6MBP75RA060, 6MBP50RTB060, 6MBP75RTB060, 6MBP25RA120

7MBP50RA060, 7MBP75RA060, 7MBP50RTB060, 7MBP75RTB060, 7MBP25RA120

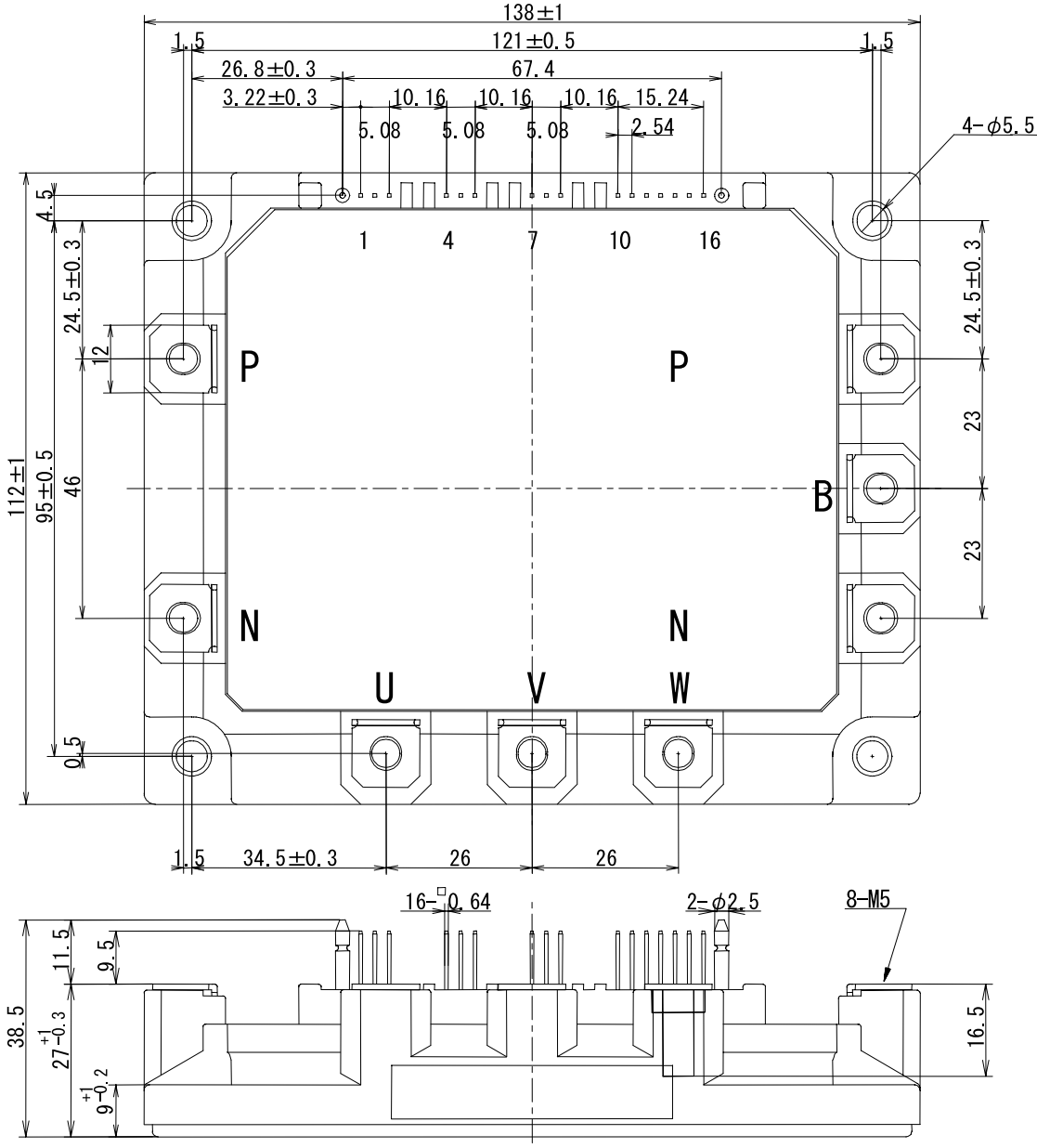

Fig. 1-5 Outline Drawing (P612)

Type name: 6MBP200RA060, 6MBP300RA060, 6MBP100RA120, 6MBP150RA120
 7MBP200RA060, 7MBP300RA060, 7MBP100RA120, 7MBP150RA120

Chapter 2

Description of Terminal Symbols and Terminology

Contents	Page
1. Description of Terminal Symbols	2-2
2. Description of Terminology	2-3

1 Description of Terminal Symbols

Main terminals

Terminal Symbol	Description
P N	Main power source Vd input terminal for the inverter bridge. P: + side, N: – side
B	Brake output terminal: terminal to connect the resistor for regenerative operation declaration
U V W	3-phase inverter output terminal
N2	Main power source Vd "negative(-)" input terminal after rectification converter smoothing of the inverter unit (P617, 619)
N1	Terminal for external connection of resistance when the OC level is to be changed (P617, 619)

Control terminals

Terminal Symbol	P610, P611 P612	P617 P619	P621 P622	Description
GND U Vcc U	<1> <3>	<1> <3>	<1> <4>	Control power source Vcc input in the upper arm U phase Vcc U: + side, GND U: – side
Vin U	<2>	<2>	<3>	Control signal input in the upper arm U phase
ALM U	–	–	<2>	Upper arm U-phase alarm output when the protection circuits are operating
GND V Vcc V	<4> <6>	<4> <6>	<5> <8>	Control power source Vcc input in the upper arm V phase Vcc V: + side, GND V: – side
Vin V	<5>	<5>	<7>	Control signal input in the upper arm V phase
ALM V	–	–	<6>	Upper arm V-phase alarm output when the protection circuits are operating
GND W Vcc W	<7> <9>	<7> <9>	<9> <12>	Control power source Vcc input in the upper arm W phase Vcc W : + side, GND W: – side
Vin W	<8>	<8>	<11>	Control signal input in the upper arm W phase
ALM W	–	–	<10>	Upper arm W-phase alarm output when the protection circuits are operating
GND Vcc	<10> <11>	<10> <11>	<13> <14>	Control power source Vcc input in the lower arm common Vcc: + side, GND: – side
Vin X	<13>	<12>	<16>	Control signal input in the lower arm X phase
Vin Y	<14>	<13>	<17>	Control signal input in the lower arm Y phase
Vin Z	<15>	<14>	<18>	Control signal input in the lower arm Z phase
Vin DB	<12>	–	<15>	Control signal input in the lower arm brake phase
ALM	<16>	<15>	<19>	Lower arm alarm output when the protection circuits are operating

2 Description of Terminology

1. Absolute Maximum Ratings

Term	Symbol	Description	
Bus voltage	V_{DC}	DC voltage that can be applied between PN terminals	
DC Bus voltage (surge)	V_{DC} (surge)	Peak value of the surge voltage that can be applied between PN terminals in switching	
DC Bus voltage (short circuit)	V_{SC}	DC source voltage between PN terminals that can be protected from short circuits/overcurrent	
Collector-emitter Voltage	V_{CES}	Maximum collector-emitter voltage of the built-in IGBT chip and repeated peak reverse voltage of the FWD chip (only the IGBT for the brake)	
Reverse voltage	V_R	Repeated peak reverse voltage of the FWD chip in the brake section	
Collector current	I_C	Maximum DC collector current for the IGBT chip	
	I_{CP}	Maximum DC pulse collector current for the IGBT chip	
	$-I_C$	Maximum DC forward current for the FWD chip	
FRD forward Current	I_F	Maximum DC forward current for the FWD chip in the brake section	
Collector power Dissipation	P_C	Maximum power dissipation for one IGBT element Power dissipation for T_j to become 150°C at $T_c = 25^\circ\text{C}$ or power dissipated in collector so that T_j becomes 150°C at $T_c = 25^\circ\text{C}$	
Control power source voltage	V_{CC}	Voltage that can be applied between GND and each V_{cc} terminal	
Input voltage	V_{in}	Voltage that can be applied between GND and each V_{in} terminal	
Input current	I_{in}	Current that flows between GND and each V_{in} terminal	
Alarm signal voltage	V_{ALM}	Voltage that can be applied between GND and ALM terminal	
Alarm signal current	I_{ALM}	Current that flows between GND and ALM terminal	
Chip junction Temperature	T_j	Maximum junction temperature of the IGBT and FWD chips during continuous operation	
Operating case temperature	T_{opr}	Range of case temperature for electrical operation (Fig. 1 shows the measuring point of the case temperature T_c)	
Storage temperature	T_{stg}	Range of ambient temperature for storage or transportation, when there is no electrical load	
Isolating voltage	V_{iso}	Maximum effective value of the sine-wave voltage between the terminals and the heat sink, when all terminals are shorted simultaneously	
Screw torque	Terminal	–	Max. torque for connection of terminal and external wire with the specified screw
	Mounting	–	Max. torque when mounting the element to the heat sink with the specified screw

Chapter 2 Description of Terminal Symbols and Terminology

2. Electrical Characteristics

2.1 Main Circuit

Term	Symbol	Description
Collector-emitter cutoff current	I_{CES}	Collector current when a specified voltage is applied between the collector and emitter of an IGBT with all input signals H (= Vz)
Collector-emitter saturation voltage	$V_{CE (sat)}$	Collector-emitter voltage at a specified collector current when the input signal of only the elements to be measured is L (= 0V) and the inputs of all other elements are H (= Vz)
Diode forward voltage	V_F	Forward voltage at a specified forward current with all input signals H (= Vz)
Turn-on time	t_{on}	The time from the input signal dropping below the threshold value until the collector current becomes 90% of the rating. See Fig. 2-3.
Turn-off time	t_{off}	The time from the input signal rising above the threshold value until the collector current becomes 10% of the rating. See Fig. 2-3.
Fall time	t_f	The time from the collector current becoming 90% at the time of IGBT turn-off until the tangent to the decreasing current becomes 10%. See Fig. 2-3.
Reverse recovery time	t_{rr}	The time required for the reverse recovery current of the built-in diode to disappear. See Fig. 2-3.

2.2 Control Circuits

Term	Symbol	Description
Control power source consumption current	I_{ccp}	Current flowing between control power source Vcc and GND on the P-side (upper arm side)
	I_{ccn}	Current flowing between control power source Vcc and GND on the N-side (lower arm side)
Input signal threshold voltage	$V_{inH (on)}$	Control signal voltage when IGBT changes from OFF to ON
	$V_{inH (off)}$	Control signal voltage when IGBT changes from ON to OFF
Input zener voltage	V_z	Voltage clamped by zener diode connected between GND and each Vin when the control signal is OFF
Signal hold time	t_{ALM}	Period in which an alarm continues to be output (ALM) from the ALM terminal after the N-side protection function is actuated
Limiting resistor for alarm	R_{ALM}	Built-in resistance limiting the primary current of the photocoupler for ALM output
Current detection shunt resistance	R1	Resistance value of the IPM built-in shunt resistor (P617, P619)

2.3 Protection Circuits

Term	Symbol	Description
Overcurrent protective operation current	I_{OC}	IGBT collector current at which the overcurrent protection (OC) works
Overcurrent cut off time	t_{DOC}	Shown in Fig. 2-1
Short-circuit protection delay time	t_{sc}	Shown in Fig. 2-2
Chip overheating protection temperature	T_{jOH}	Tripping temperature at which the IGBT chip junction temperature Tj overheats and IGBT soft shutdown is performed
Chip overheating protection hysteresis	T_{jH}	Drop temperature required for output stop resetting after protection operation
Case overheating protection temperature	T_{cOH}	Tripping temperature at which the IGBT performs soft shutdown when the case temperature Tc shows overheating
Case overheating protection hysteresis	T_{cH}	Drop temperature required for output stop resetting after protection operation
Under voltage protection level	V_{UV}	Tripping voltage at which the IGBT performs soft shutdown when the control power source voltage Vcc drops
Control power source undervoltage protection hysteresis	V_H	Recovery voltage required for output stop resetting after protection operation

Chapter 2 Description of Terminal Symbols and Terminology

3. Thermal Characteristics

Term	Symbol	Description
Chip-case thermal resistance	$R_{th(j-c)}$	Chip-case thermal resistance of IGBT or diode
Chip-fin thermal resistance	$R_{th(c-f)}$	Thermal resistance between the case and heat sink, when mounted on a heat sink at the recommended torque using the thermal compound
Case temperature	T_c	IPM case temperature (temperature of the copper plate directly under the IGBT or the diode)

4. Noise Tolerance

Term	Symbol	Description
Common mode noise	–	Common mode noise tolerance in our test circuit
Electric surge	–	Electric surge tolerance in our test circuit

5. Other

Term	Symbol	Description
Weight	W_t	Weight of IPM
Switching frequency	f_{sw}	Range of control signal frequencies for input to the control signal input terminal
Reverse recovery current	I_{rr}	Shown in Fig. 2-3
Reverse bias safe operation area	RBSOA	Area of the current and voltage in which IGBT can be cut off under specified conditions during turn-off
Switching loss	E_{on}	IGBT switching loss during turn-on
	E_{off}	IGBT switching loss during turn-off
	E_{rr}	FWD switching loss during reverse recovery

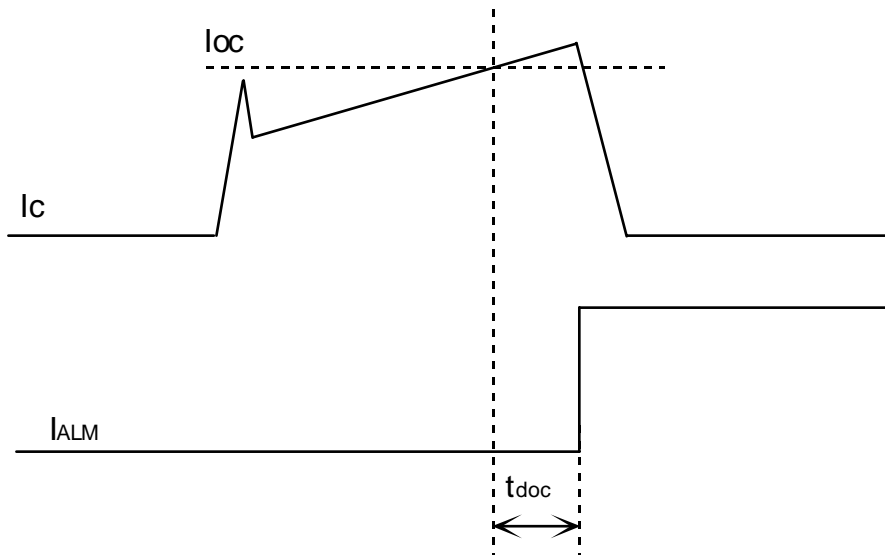

Fig. 2-1 Overcurrent Protection Delay Time (t_{doc})

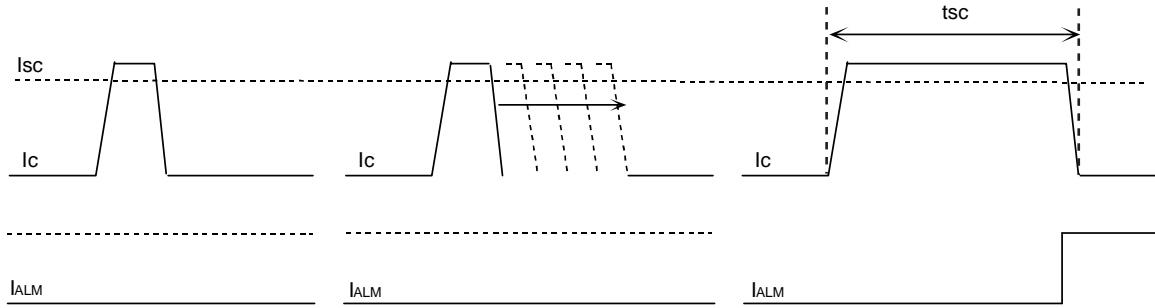

Fig. 2-2 Short-circuit Protection Delay Time (t_{sc})

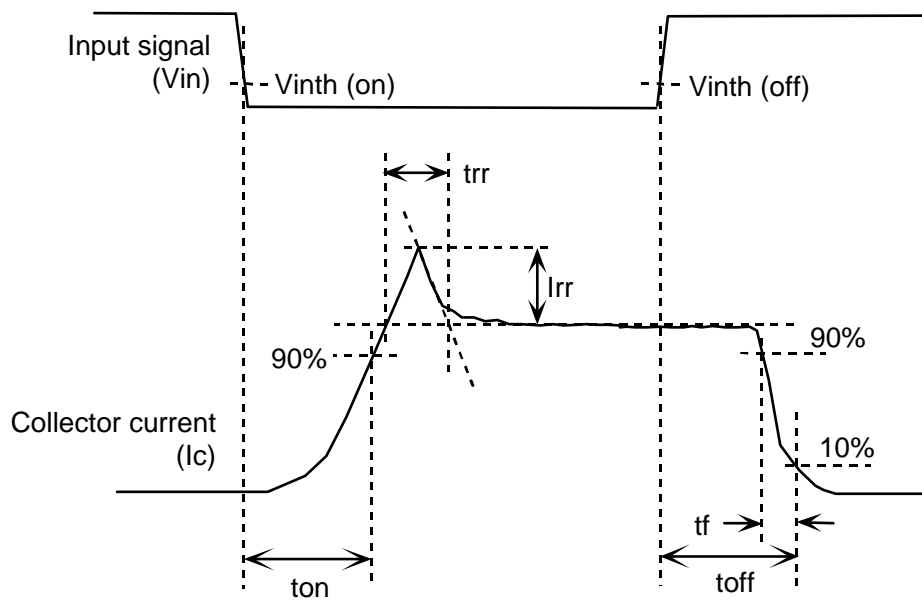

Fig. 2-3 Switching Time

Chapter 3

Description of Functions

Contents	Page
1. Function Tables	3-2
2. Function Descriptions	3-4
3. Truth Tables	3-11
4. IPM Block Diagrams	3-13
5. Timing Charts	3-21

1 Function Tables

The functions built into the IPM are shown in Tables 3-1 to 3-3.

Table 3-1 IPM Built-in Functions (R-IPM)

600 V system

Element Number	Model	Built-in Functions								Package
		Common for Upper and Lower Arm			Upper Arm		Lower Arm		TcOH	
		Dr	UV	TjOH	OC	ALM	OC	ALM		
6 in 1	6MBP15RH060	√	√	√	–	–	√	√	–	P617
	6MBP20RH060	√	√	√	–	–	√	√	–	P617
	6MBP30RH060	√	√	√	–	–	√	√	–	P617
	6MBP50RA060	√	√	√	√	–	√	√	√	P610
	6MBP75RA060	√	√	√	√	–	√	√	√	P610
	6MBP100RA060	√	√	√	√	–	√	√	√	P611
	6MBP150RA060	√	√	√	√	–	√	√	√	P611
	6MBP200RA060	√	√	√	√	–	√	√	√	P612
	6MBP300RA060	√	√	√	√	–	√	√	√	P612
7 in 1	7MBP50RA060	√	√	√	√	–	√	√	√	P610
	7MBP75RA060	√	√	√	√	–	√	√	√	P610
	7MBP100RA060	√	√	√	√	–	√	√	√	P611
	7MBP150RA060	√	√	√	√	–	√	√	√	P611
	7MBP200RA060	√	√	√	√	–	√	√	√	P612
	7MBP300RA060	√	√	√	√	–	√	√	√	P612

1200 V system

Element Number	Model	Built-in Functions								Package
		Common for Upper and Lower Arm			Upper Arm		Lower Arm		TcOH	
		Dr	UV	TjOH	OC	ALM	OC	ALM		
6 in 1	6MBP15RA120	√	√	√	–	–	√	√	–	P619
	6MBP25RA120	√	√	√	√	–	√	√	√	P610
	6MBP50RA120	√	√	√	√	–	√	√	√	P611
	6MBP75RA120	√	√	√	√	–	√	√	√	P611
	6MBP100RA120	√	√	√	√	–	√	√	√	P612
	6MBP150RA120	√	√	√	√	–	√	√	√	P612
7 in 1	7MBP25RA120	√	√	√	√	–	√	√	√	P610
	7MBP50RA120	√	√	√	√	–	√	√	√	P611
	7MBP75RA120	√	√	√	√	–	√	√	√	P611
	7MBP100RA120	√	√	√	√	–	√	√	√	P612
	7MBP150RA120	√	√	√	√	–	√	√	√	P612
6 in 1	6MBP25RJ120	√	√	√	√	√	√	√	√	P621
	6MBP50RJ120	√	√	√	√	√	√	√	√	P621
	6MBP75RJ120	√	√	√	√	√	√	√	√	P621
7 in 1	7MBP25RJ120	√	√	√	√	√	√	√	√	P621
	7MBP50RJ120	√	√	√	√	√	√	√	√	P621
	7MBP75RJ120	√	√	√	√	√	√	√	√	P621

Dr: IGBT drive circuit, UV: Control power source undervoltage protection, TjOH: Element overheating protection, OC: Overcurrent protection, ALM: Alarm output, TcOH: Case overheating protection

Table 3-2 IPM Built-in Functions (R-IPM3)

600 V system

Element Number	Model	Built-in Functions								Package
		Common for Upper and Lower Arm			Upper Arm		Lower Arm		TcOH	
		Dr	UV	TjOH	OC	ALM	OC	ALM		
6 in 1	6MBP20RTA060	√	√	√	–	–	√	√	–	P619
	6MBP50RTB060	√	√	√	√	–	√	√	√	P610
	6MBP75RTB060	√	√	√	√	–	√	√	√	P610
	6MBP100RTB060	√	√	√	√	–	√	√	√	P611
	6MBP150RTB060	√	√	√	√	–	√	√	√	P611
7 in 1	7MBP50RTB060	√	√	√	√	–	√	√	√	P610
	7MBP75RTB060	√	√	√	√	–	√	√	√	P610
	7MBP100RTB060	√	√	√	√	–	√	√	√	P611
	7MBP150RTB060	√	√	√	√	–	√	√	√	P611
6 in 1	6MBP50RTJ060	√	√	√	√	√	√	√	√	P621
	6MBP75RTJ060	√	√	√	√	√	√	√	√	P621
	6MBP100RTJ060	√	√	√	√	√	√	√	√	P621
	6MBP150RTJ060	√	√	√	√	√	√	√	√	P621
7 in 1	7MBP50RTJ060	√	√	√	√	√	√	√	√	P621
	7MBP75RTJ060	√	√	√	√	√	√	√	√	P621
	7MBP100RTJ060	√	√	√	√	√	√	√	√	P621
	7MBP150RTJ060	√	√	√	√	√	√	√	√	P621

Dr: IGBT drive circuit, UV: Control power source undervoltage protection, TjOH: Element overheating protection, OC: Overcurrent protection, LM: Alarm output, TcOH: Case overheating protection

Table 3-3 IPM Built-in Functions (Econo IPM)

600 V system

Element Number	Model	Built-in Functions								Package	
		Common for Upper and Lower Arm			Upper Arm		Lower Arm		TcOH		
		Dr	UV	TjOH	OC	ALM	OC	ALM			
6 in 1	6MBP50TEA060	√	√	√	√	√	√	√	√	–	P622
	6MBP75TEA060	√	√	√	√	√	√	√	√	–	P622
	6MBP100TEA060	√	√	√	√	√	√	√	√	–	P622
	6MBP150TEA060	√	√	√	√	√	√	√	√	–	P622
7 in 1	7MBP50TEA060	√	√	√	√	√	√	√	√	–	P622
	7MBP75TEA060	√	√	√	√	√	√	√	√	–	P622
	7MBP100TEA060	√	√	√	√	√	√	√	√	–	P622
	7MBP150TEA060	√	√	√	√	√	√	√	√	–	P622

1200 V system

Element Number	Model	Built-in Functions								Package	
		Common for Upper and Lower Arm			Upper Arm		Lower Arm		TcOH		
		Dr	UV	TjOH	OC	ALM	OC	ALM			
6 in 1	6MBP25TEA120	√	√	√	√	√	√	√	√	–	P622
	6MBP50TEA120	√	√	√	√	√	√	√	√	–	P622
	6MBP75TEA120	√	√	√	√	√	√	√	√	–	P622
7 in 1	7MBP25TEA120	√	√	√	√	√	√	√	√	–	P622
	7MBP50TEA120	√	√	√	√	√	√	√	√	–	P622
	7MBP75TEA120	√	√	√	√	√	√	√	√	–	P622

Dr: IGBT drive circuit, UV: Control power source undervoltage protection, TjOH: Element overheating protection, OC: Overcurrent protection, ALM: Alarm output, TcOH: Case overheating protection

2 Function Descriptions

2.1 IGBT, FWD for 3-phase inverters

As shown in Fig. 3-1, IGBT and FWD for 3-phase inverters are built in, and a 3-phase bridge circuit is formed inside the IPM. The main circuit is completed by connecting the main power source to the P and N terminals and the 3-phase output lines to the U, V, and W terminals. Connect a snubber circuit to suppress the surge voltages.

2.2 IGBT, FWD for brake

As shown in Fig. 3-1, IGBT and FWD for brake are built in, and an IGBT collector is connected internally to the B terminal. By controlling the brake IGBT through connection of brake resistance between the terminals P and B, the regeneration energy can be dissipated while decelerating to suppress the rise of voltage between the P and N terminals.

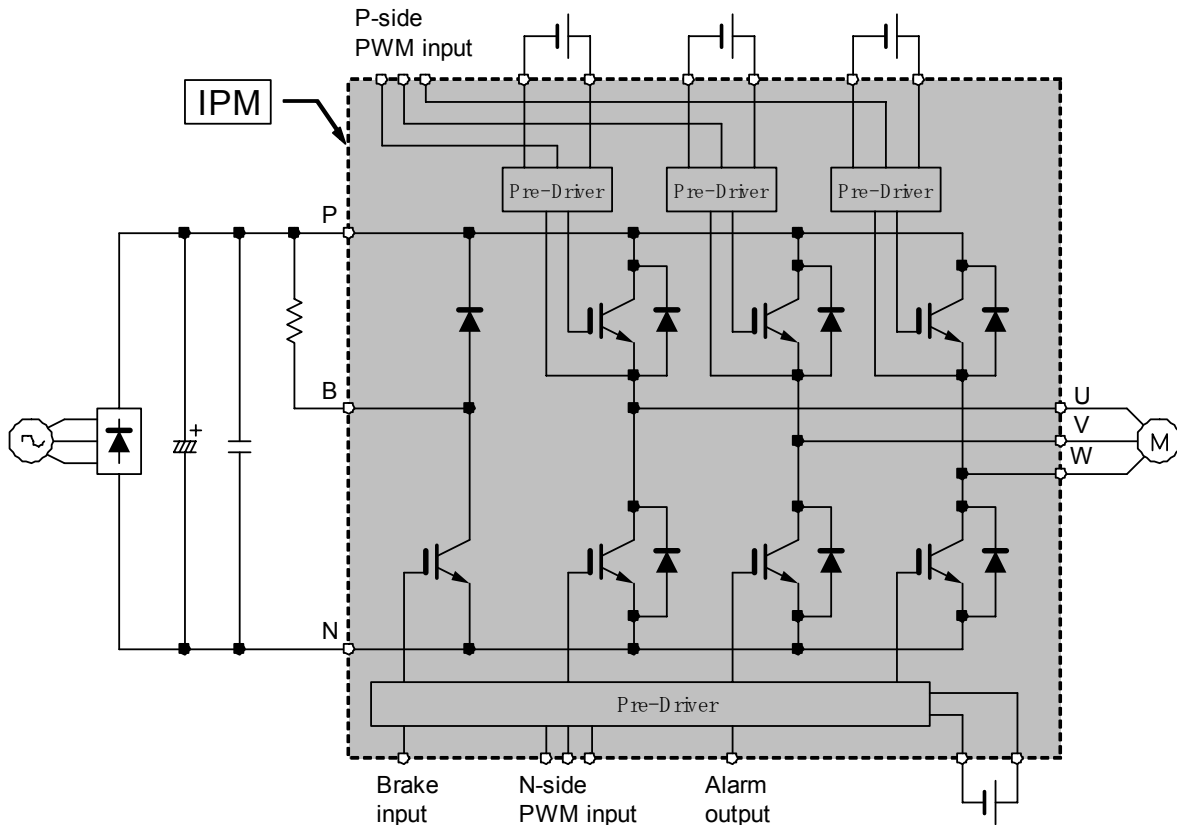

Fig. 3-1 3-Phase Inverter Application Model (in Case of 7MBP150RTB060)

2.3 IGBT drive function

Fig. 3-2 shows the pre-driver block diagram. As the IPM incorporates an IGBT drive function, the IGBT can be driven without designing a gate resistance value by connecting the photocoupler output to the IPM. The features of this drive function are introduced below.

- Independent gate resistance control
A special turn-on/turn-off R_g not using any exclusive gate resistance R_g is built in. With this, the dv/dt of turn-on and turn-off can be controlled individually, so that the merits of the element are fully demonstrated (Turn on/Normal Shutdown).
- Soft shutdown
During an overcurrent or other abnormality, the gate voltage is lowered softly and gently to prevent element destruction by surge voltage (Soft Shutdown).
- Erroneous ON prevention
Since a circuit is set up to ground the gate electrode with low impedance while OFF, erroneous ON caused by the rise of V_{GE} due to noise can be prevented (Off Hold).

- A reverse bias power source is not required.

As the IPM has a short wiring between the drive circuit and the IGBT, the wiring impedance is small, making driving without reverse bias possible.

- Alarm latch

Alarms have a latch period of approximately 2 ms, and the IGBT does not operate even when an On-signal enters during the latch period. In addition, as the alarms for each phase, including brake, on the lower arm side are connected mutually, all IGBTs on the lower arm side are stopped for the latch period when a protection operation is performed on the lower arm side.

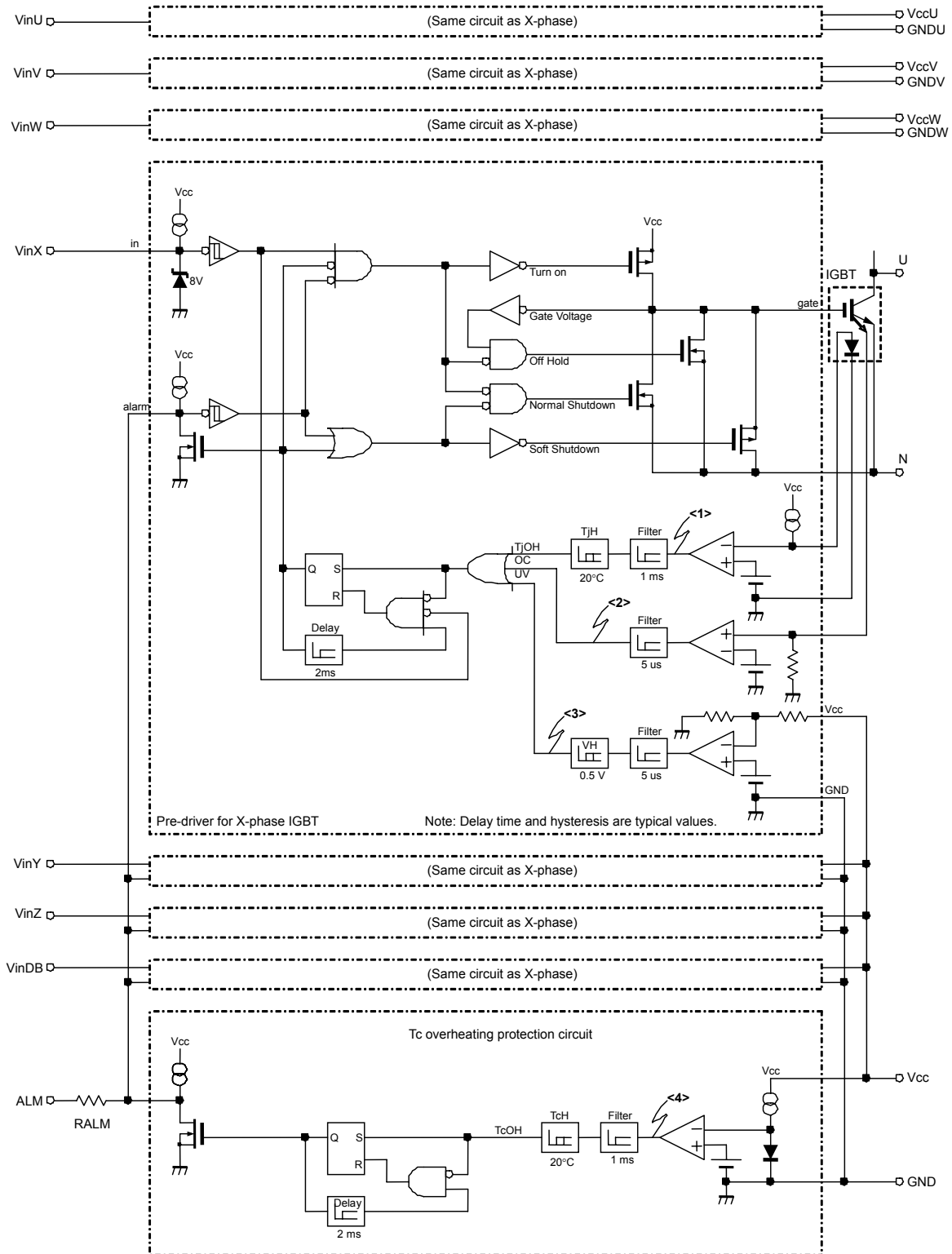

Fig. 3-2 IPM Function Block (Representative Model: 7MBP150RTB060)

2.4 Overcurrent protection function (OC)

Two detection methods are used, the sense IGBT method and the shunt resistance method.

(1) Sense IGBT method

Models: P610/P611/P612/P621/P622

- The main current flowing in the IGBT is detected by taking the sense current flowing in the current sense IGBT inside the IGBT chip into the control circuit. The sense current is extremely small in comparison with the main current, so that the detection loss can be kept minimal in comparison with the shunt resistance method.
- When the overcurrent protection loc level is exceeded for a duration of approximately 5 μ s (tdoc), the IGBT goes through a soft shutdown. As a detection filter is installed, faulty operations caused by instantaneous overcurrents or noise can be prevented.
- When after approximately 2 ms the level drops below loc and the input signal is OFF, the alarm is released.

(2) Shunt resistance method

Models: P617/P619

- Overcurrent protection is performed by detecting the voltage at both ends of the current detection shunt resistance R1, connected to the DC bus bar line N. When the overcurrent detection level loc is exceeded for a duration of approximately 5 μ s (tdoc), the IGBT goes through a soft shutdown. As a detection filter is installed, faulty operations caused by instantaneous overcurrents or noise can be prevented.
- When after approximately 2 ms the level drops below loc and if the input signal is OFF, the alarm is released.

2.5 Short-circuit protection function (SC)

The SC protection function always operates with the OC protection function to suppress the peak current when a load or arm is shorted.

2.6 Undervoltage protection (UV)

- The UV protection function performs soft shutdown of the IGBT when the control source voltage (Vcc) continuously drops below VUV for approximately 5 μ s.
- As the hysteresis VH is provided, the alarm is released if Vcc recovers to VUV + VH or more after approximately 2 ms and the input signal is OFF.

2.7 Case temperature overheating protection function (TcOH)

- The TcOH protection function detects the insulating substrate temperature with the temperature detection elements set up on the same ceramic substrate as that on which the power chips (IGBT, FWD) are set up and performs soft shutdown of the IGBT when the detected temperature exceeds the protection level TcOH continuously for approximately 1 ms.
- As the hysteresis TcH is provided, the alarm is released if Tc drops below TcOH-TcH after approximately 2 ms.
- The TcOH detection positions are shown in Fig.3-3 to Fig.3-6.

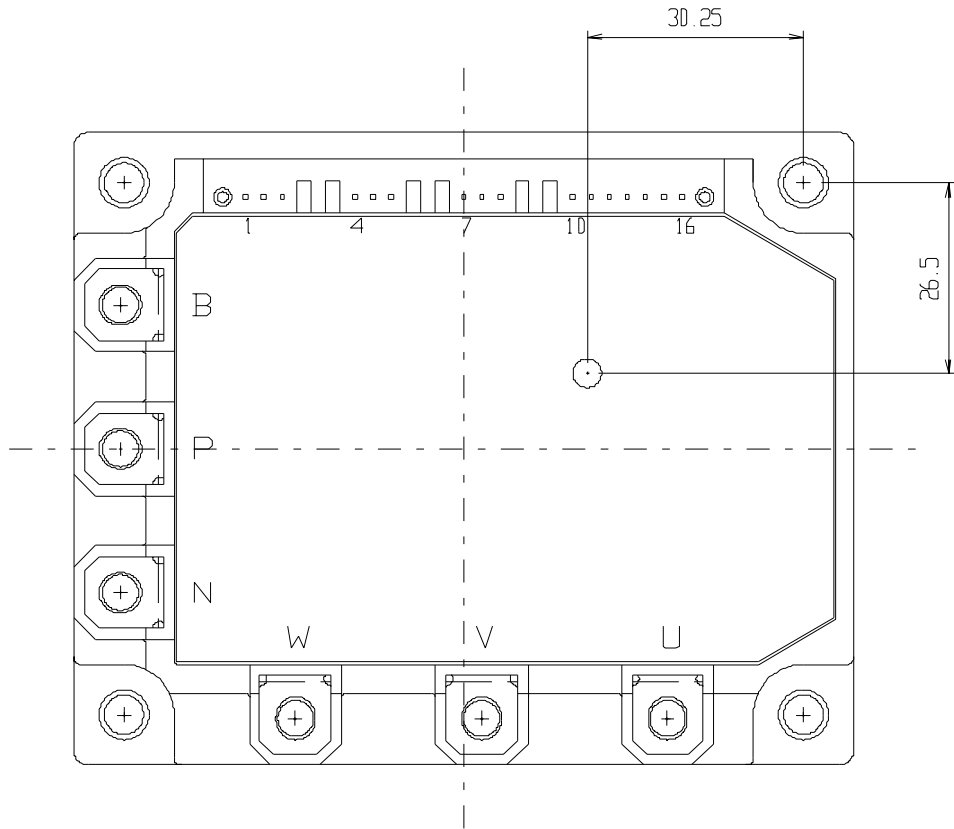

Fig. 3-3 TcOH Detection Position (P610)

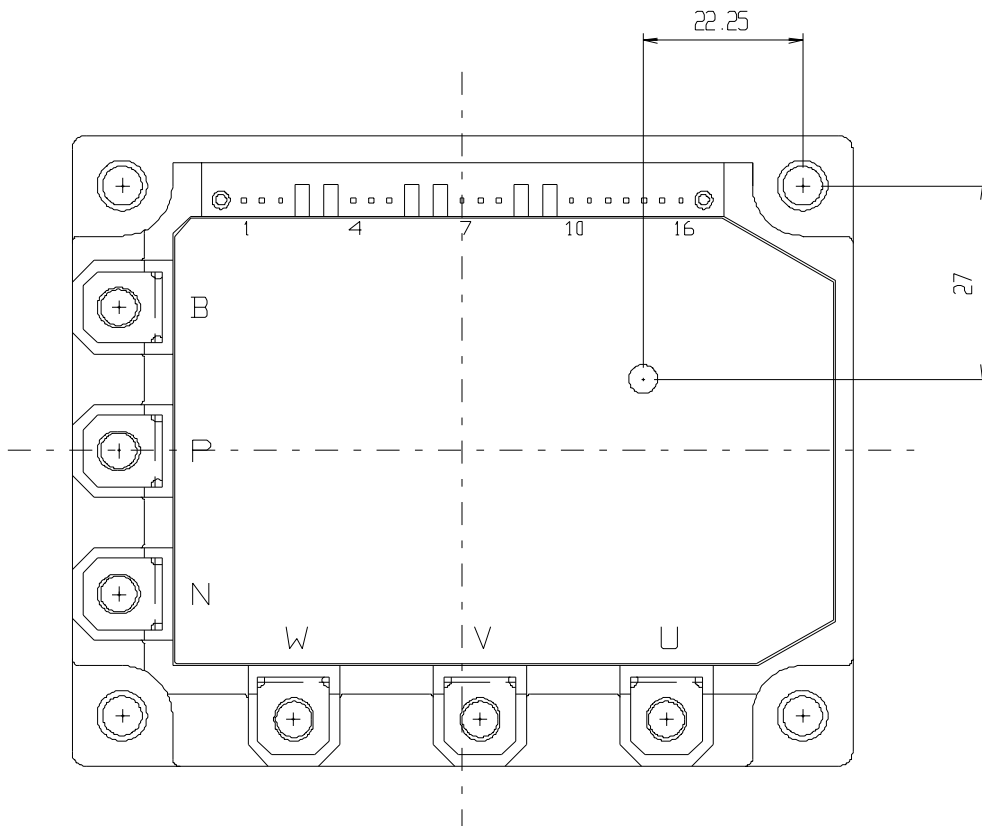

Fig. 3-4 TcOH Detection Position (P611)

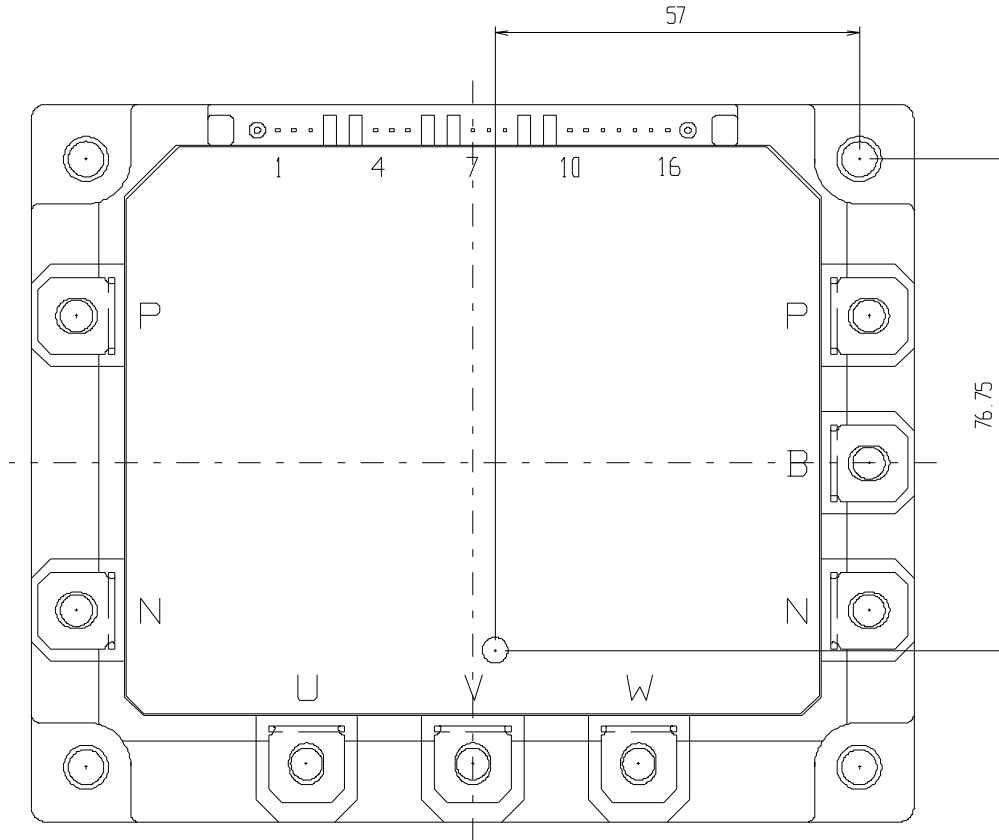

Fig. 3-5 TcOH Detection Position (P612)

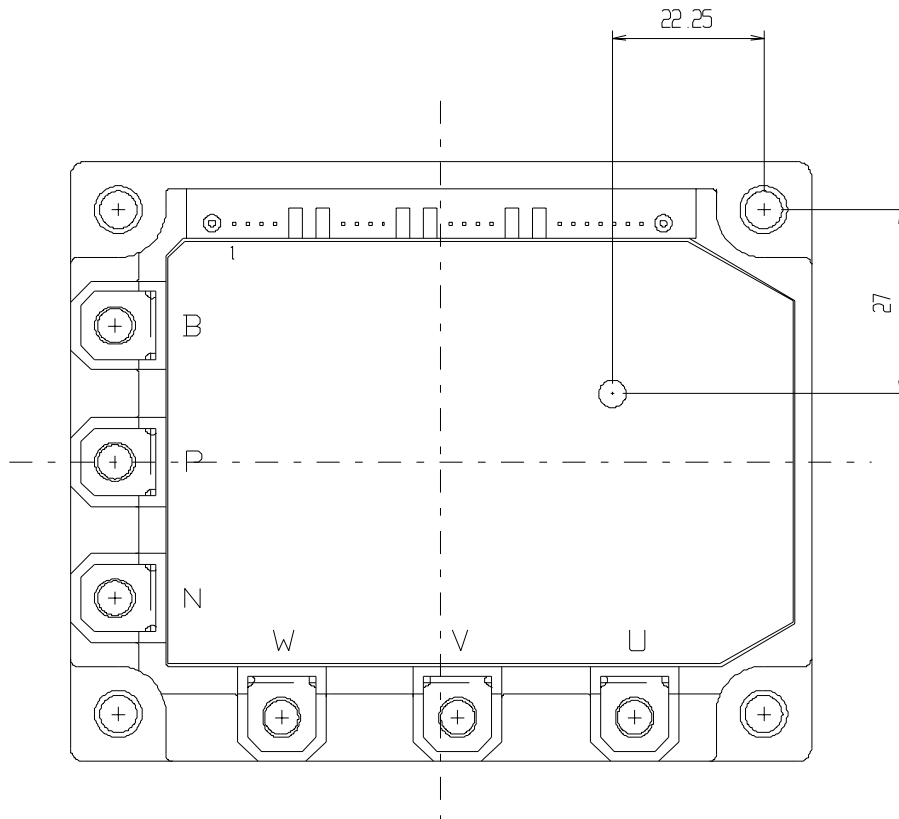

Fig. 3-6 TcOH Detection Position (P621)

2.8 Chip temperature overheating protection function (TjOH)

- The TjOH protection function detects the IGBT chip temperature with the temperature detection elements set up on all IGBT chips and performs soft shutdown of the IGBT when the detected temperature exceeds the protection level (TjOH) continuously for approximately 1 ms or more.
- As the hysteresis TjH is provided, the alarm is released if Tj drops below TjOH-TjH after approximately 2 ms and the input signal is OFF.

2.9 Alarm output function (ALM)

- When a protection function operates, the alarm output terminal becomes conductive against each reference potential GND. With open collector output, a function for direct drive of the photocoupler is provided, and a 1.5 kΩ series resistor is built in.
- When a protection function operates, the alarm signal is output continuously for approximately 2 ms (tALM). The alarm is released when the alarm cause has been removed, tALM has elapsed, and the input signal is OFF. When the cause is TcOH, the alarm is released regardless of the input signal.
- As the alarm terminals of the drive circuit on the lower arm side are connected mutually, all IGBTs on the lower arm side, including the brake, are stopped when any one of the IGBTs outputs an alarm.

3 Truth Tables

The truth tables when a fault occurs are shown in Tables 3-4 to 3-7.

Table 3-4 Truth Table (P617, P619)

	Cause of Fault	IGBT				Alarm Output Low Side
		U-phase	V-phase	W-phase	Low Side	
High side U-phase	UV	OFF	*	*	*	High
	TjOH	OFF	*	*	*	High
High side V-phase	UV	*	OFF	*	*	High
	TjOH	*	OFF	*	*	High
High side W-phase	UV	*	*	OFF	*	High
	TjOH	*	*	OFF	*	High
Low side	OC	*	*	*	OFF	Low
	UV	*	*	*	OFF	Low
	TjOH	*	*	*	OFF	Low

* Depends on input logic

Table 3-5 Truth Table (P610, P611, P612)

	Cause of Fault	IGBT				Alarm Output
		U-phase	V-phase	W-phase	Low Side	Low Side
High side U-phase	OC	OFF	*	*	*	High
	UV	OFF	*	*	*	High
	TjOH	OFF	*	*	*	High
High side V-phase	OC	*	OFF	*	*	High
	UV	*	OFF	*	*	High
	TjOH	*	OFF	*	*	High
High side W-phase	OC	*	*	OFF	*	High
	UV	*	*	OFF	*	High
	TjOH	*	*	OFF	*	High
Low side	OC	*	*	*	OFF	Low
	UV	*	*	*	OFF	Low
	TjOH	*	*	*	OFF	Low
	TcOH	*	*	*	OFF	Low

* Depends on input logic

Table 3-6 Truth Table (P621)

	Cause of Fault	IGBT				Alarm Output			
		U-phase	V-phase	W-phase	Low Side	ALMU	ALMV	ALMW	ALM
High side U-phase	OC	OFF	*	*	*	Low	High	High	High
	UV	OFF	*	*	*	Low	High	High	High
	TjOH	OFF	*	*	*	Low	High	High	High
High side V-phase	OC	*	OFF	*	*	High	Low	High	High
	UV	*	OFF	*	*	High	Low	High	High
	TjOH	*	OFF	*	*	High	Low	High	High
High side W-phase	OC	*	*	OFF	*	High	High	Low	High
	UV	*	*	OFF	*	High	High	Low	High
	TjOH	*	*	OFF	*	High	High	Low	High
Low side	OC	*	*	*	OFF	High	High	High	Low
	UV	*	*	*	OFF	High	High	High	Low
	TjOH	*	*	*	OFF	High	High	High	Low
	TcOH	*	*	*	OFF	High	High	High	Low

* Depends on input logic

Table 3-7 Truth Table (P622)

	Cause of Fault	IGBT				Alarm Output			
		U-phase	V-phase	W-phase	Low Side	ALMU	ALMV	ALMW	ALM
High side U-phase	OC	OFF	*	*	*	Low	High	High	High
	UV	OFF	*	*	*	Low	High	High	High
	TjOH	OFF	*	*	*	Low	High	High	High
High side V-phase	OC	*	OFF	*	*	High	Low	High	High
	UV	*	OFF	*	*	High	Low	High	High
	TjOH	*	OFF	*	*	High	Low	High	High
High side W-phase	OC	*	*	OFF	*	High	High	Low	High
	UV	*	*	OFF	*	High	High	Low	High
	TjOH	*	*	OFF	*	High	High	Low	High
Low side	OC	*	*	*	OFF	High	High	High	Low
	UV	*	*	*	OFF	High	High	High	Low
	TjOH	*	*	*	OFF	High	High	High	Low

* Depends on input logic

4 IPM Block Diagrams

The IPM block diagrams are shown in Fig. 3-7 to Fig. 3-14.

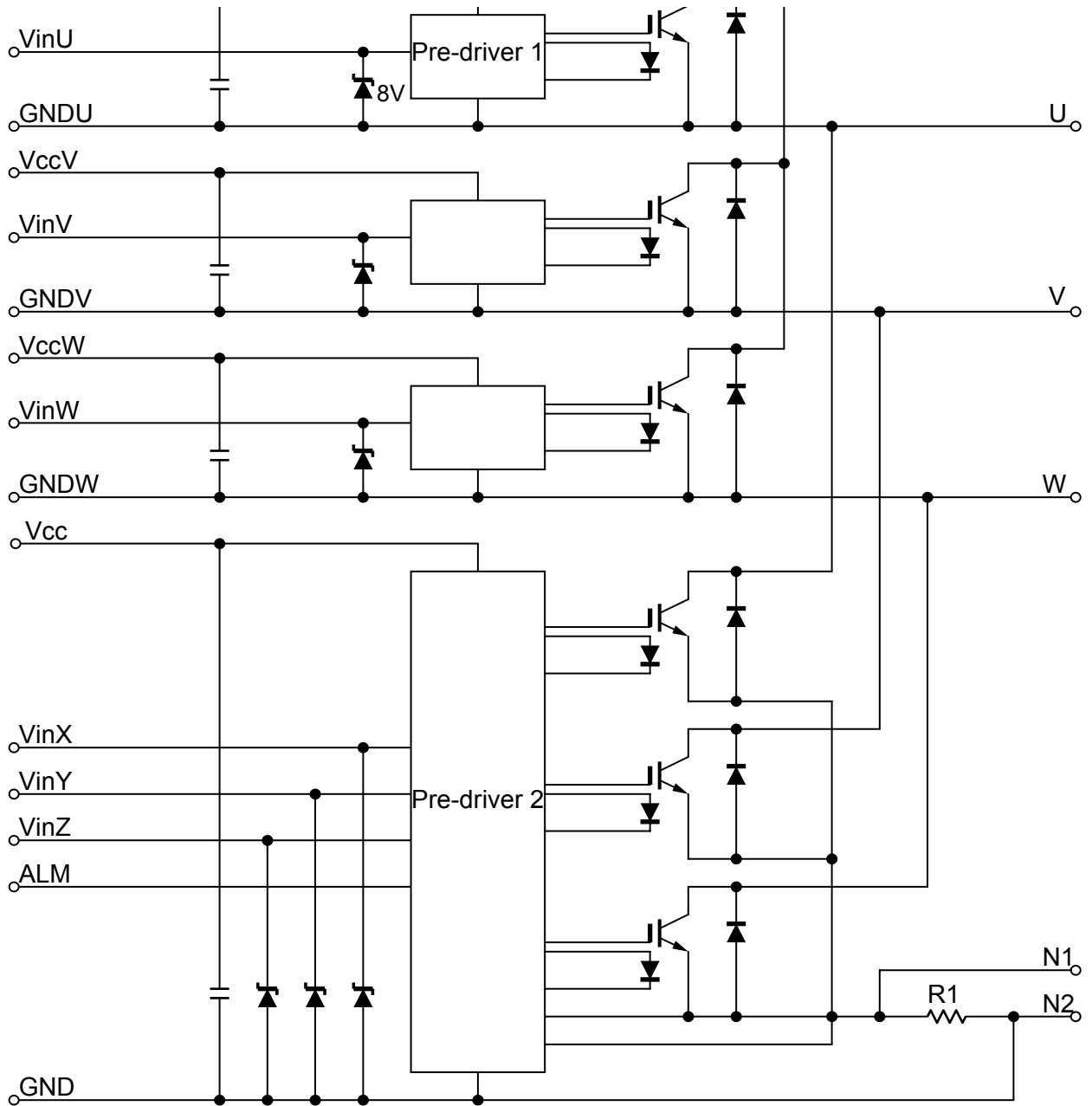

Fig. 3-7 IPM Block Diagram (P617)

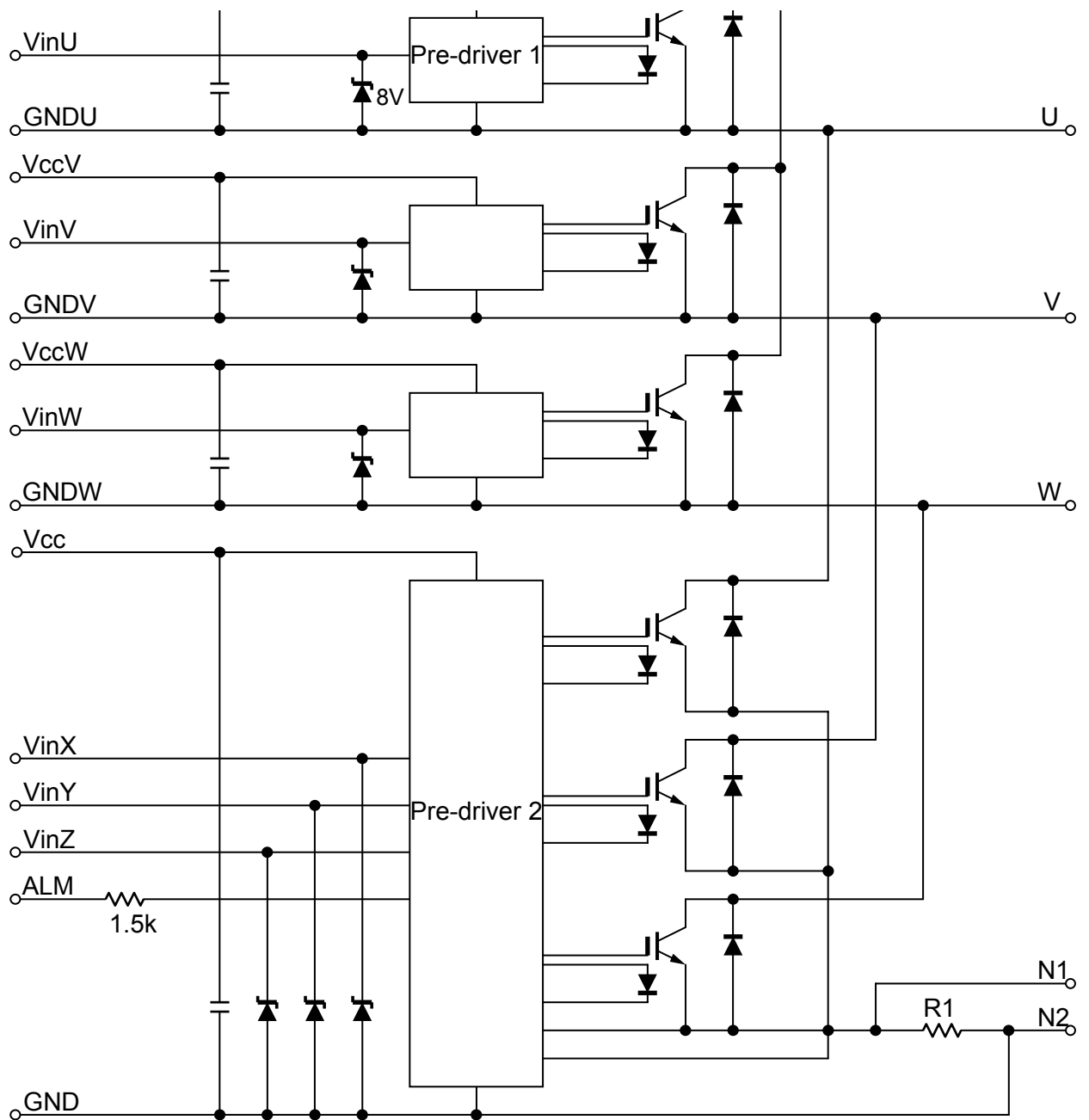

Fig. 3-8 IPM Block Diagram (P619)

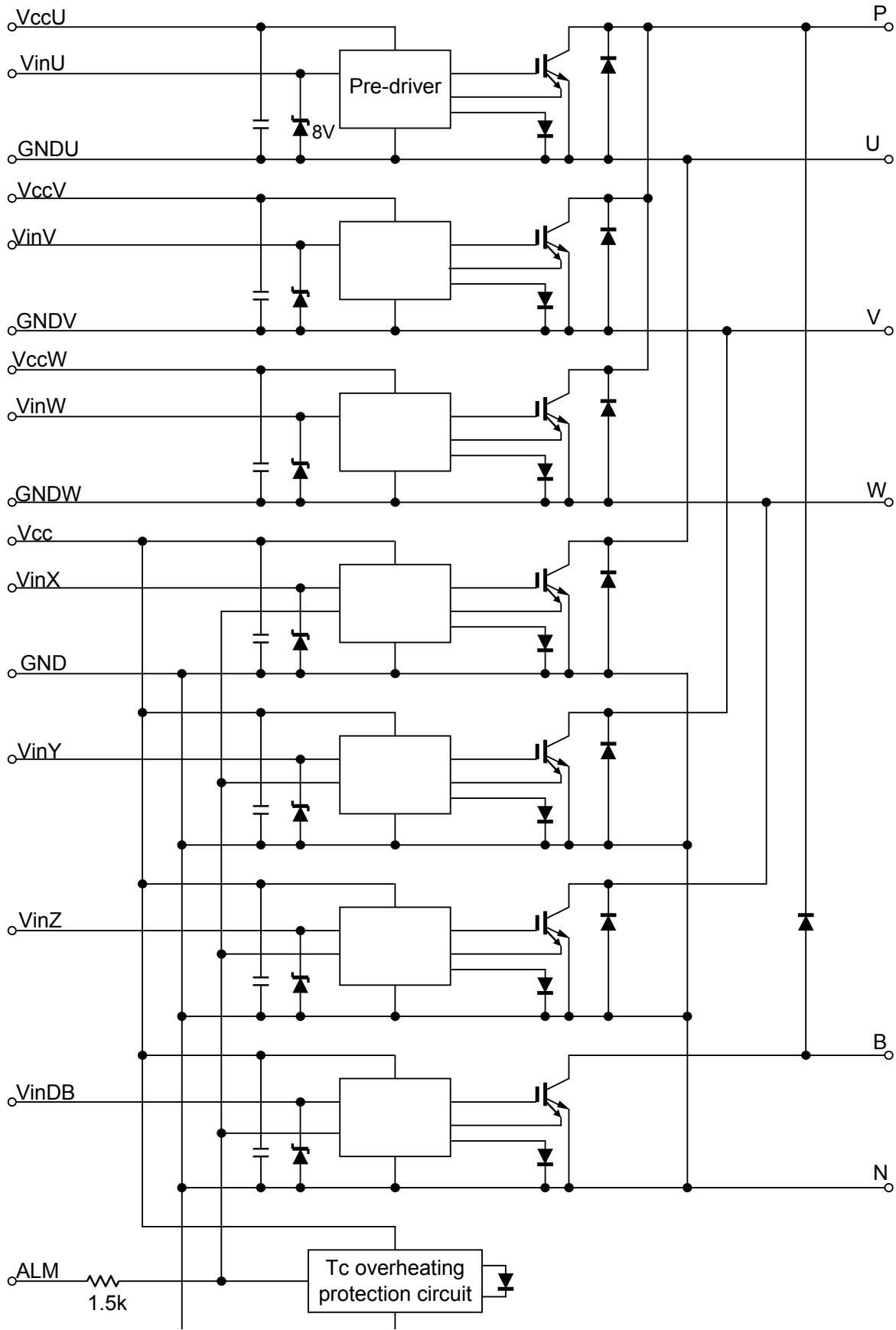

Fig. 3-9 IPM Block Diagram (P610, P611, P612 with Built-in Brake)

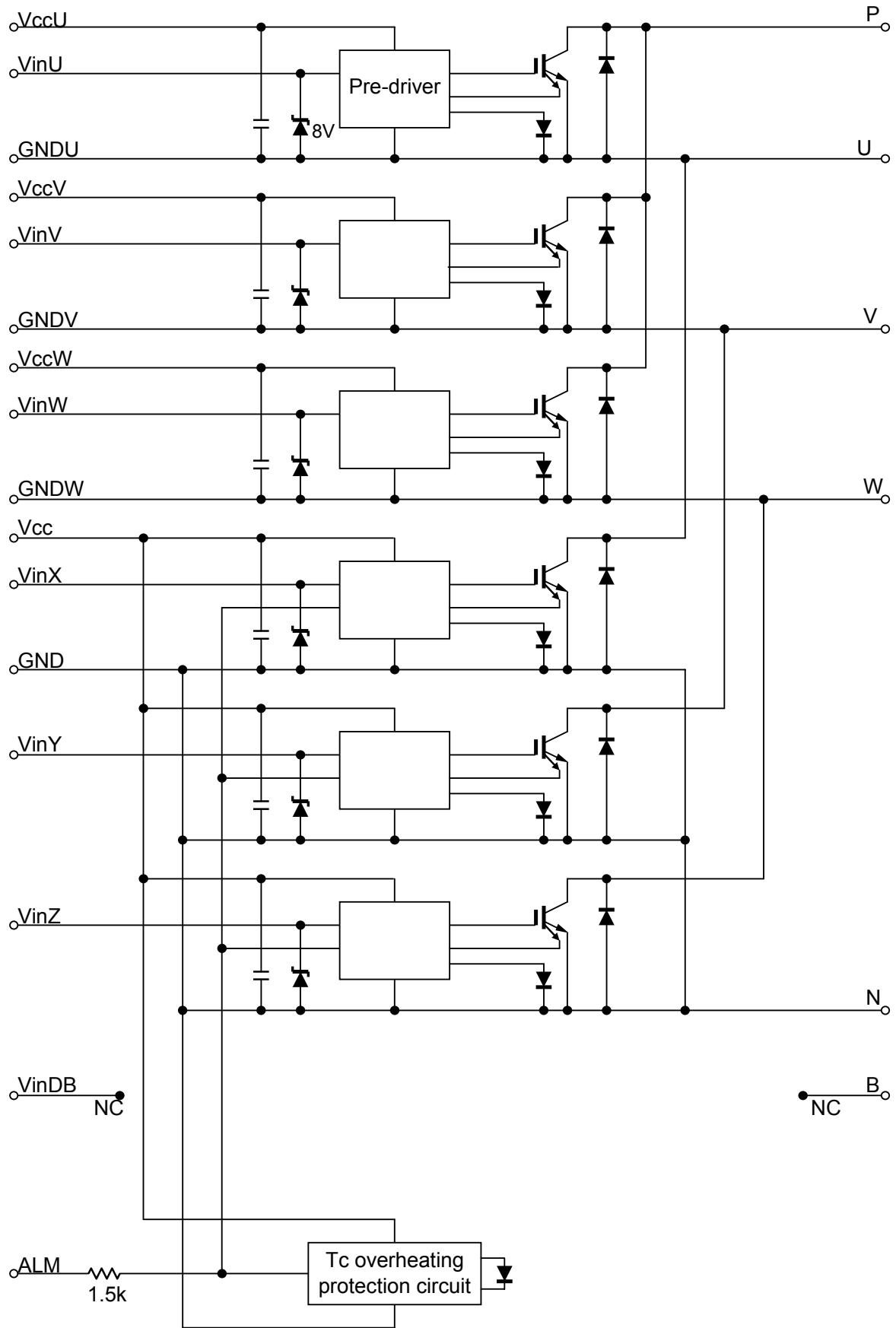

Fig. 3-10 IPM Block Diagram (P610, P611, P612 Without Brake)

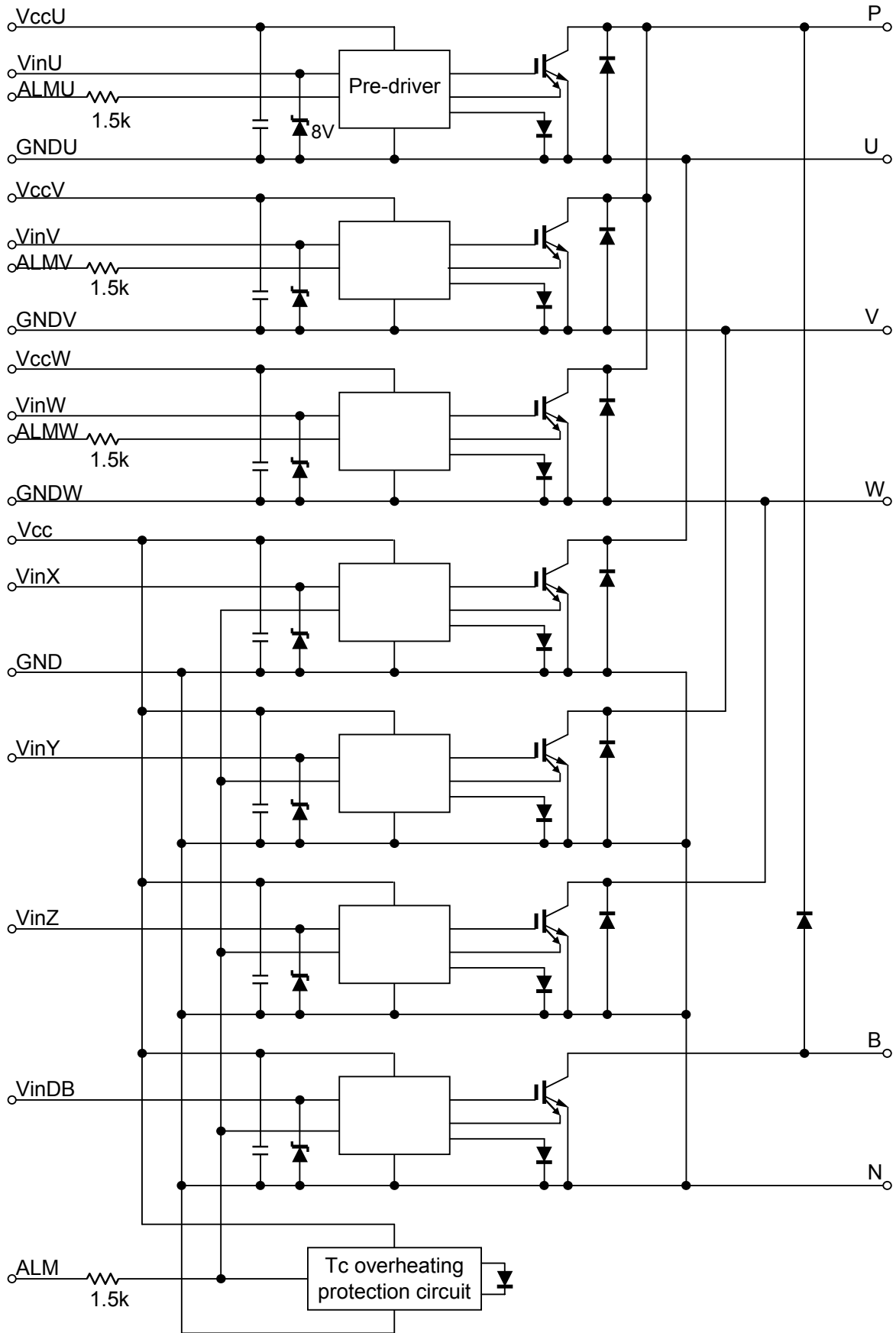

Fig. 3-11 IPM Block Diagram (P621 with Built-in Brake)

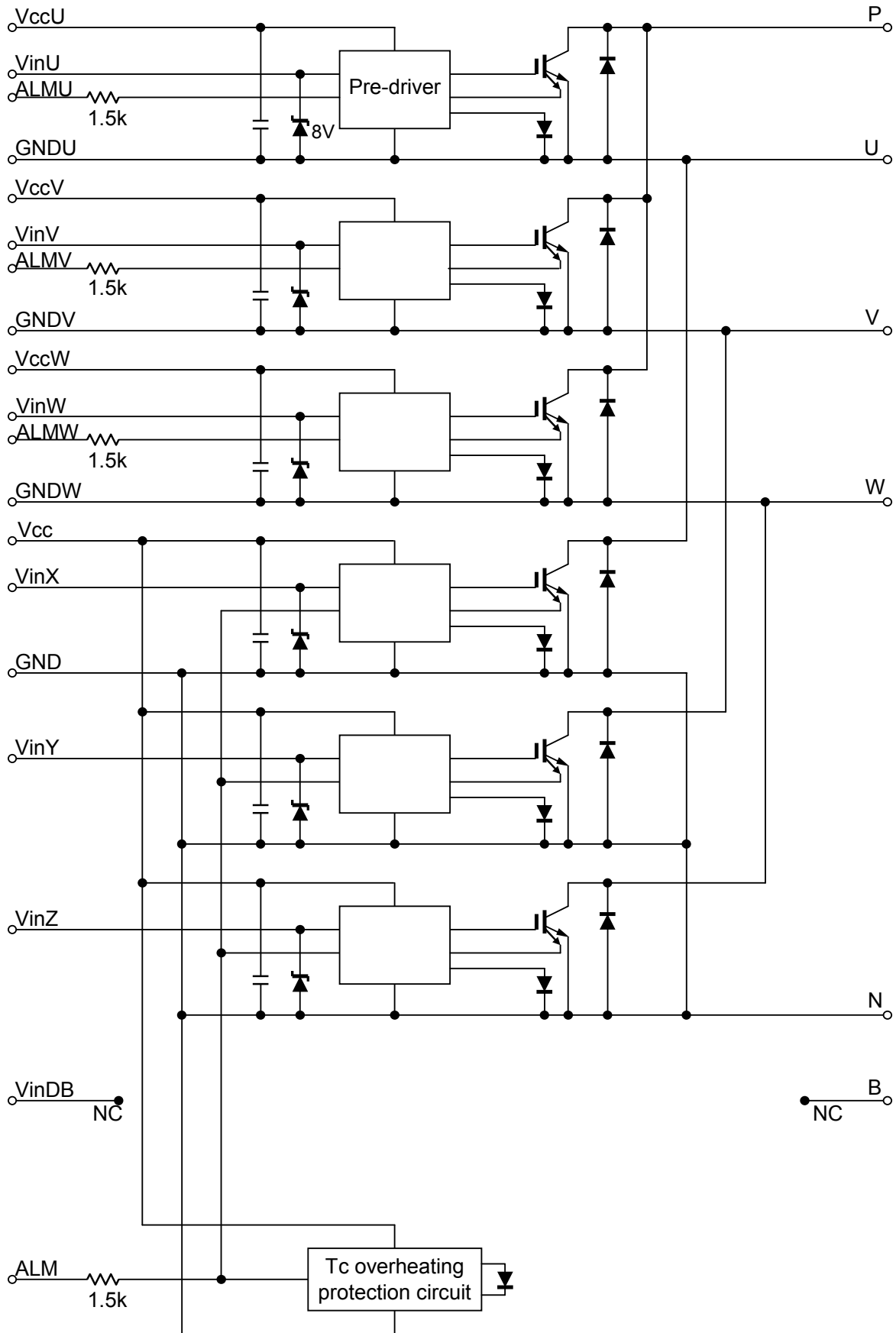

Fig. 3-12 IPM Block Diagram (P621 Without Brake)

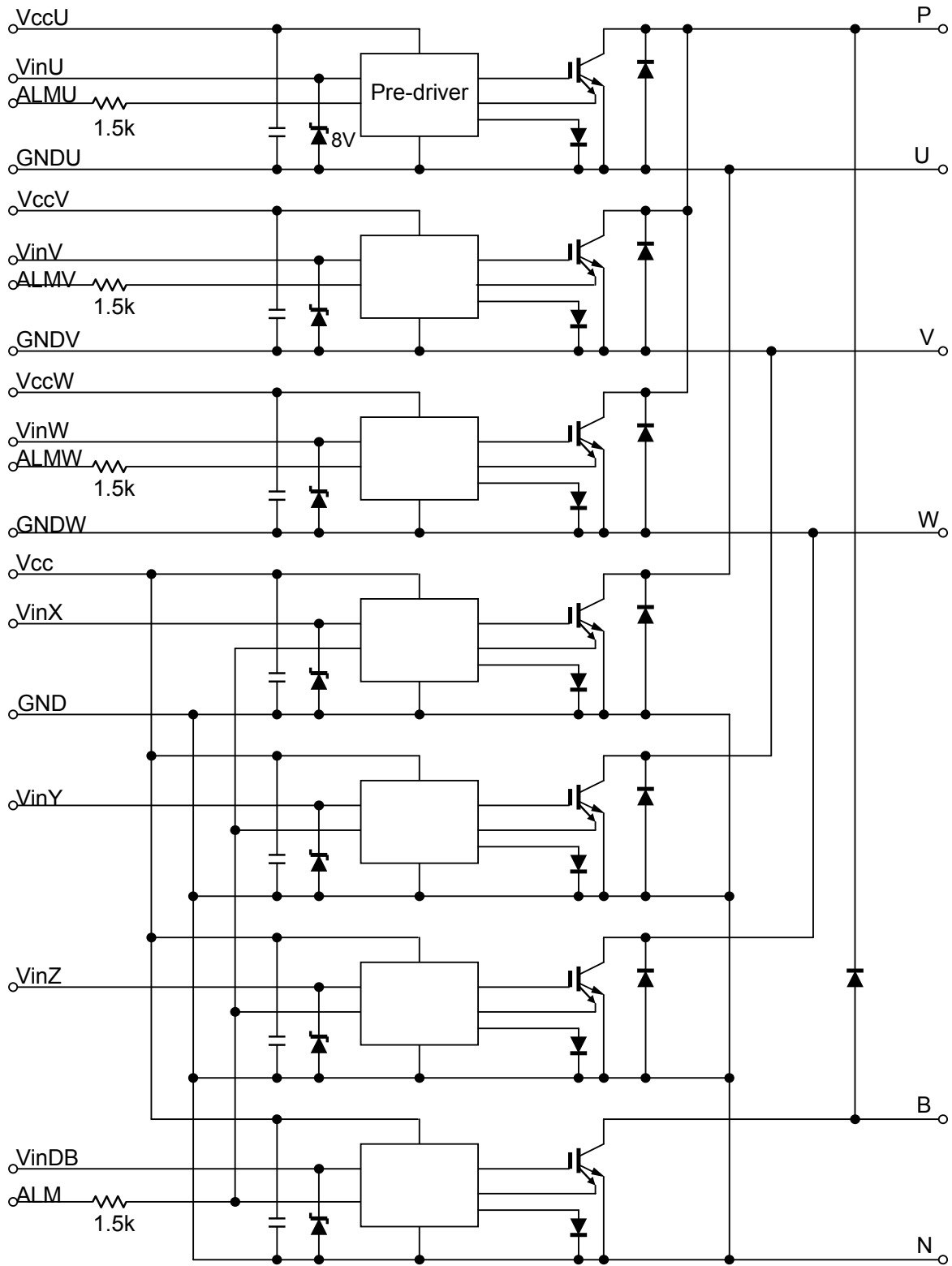

Fig. 3-13 IPM Block Diagram (P622 with Built-in Brake)

5 Timing Charts

The timing charts for the protection functions are shown in Fig. 3-15 to Fig. 3-21.

Undervoltage protection (UV) (1)

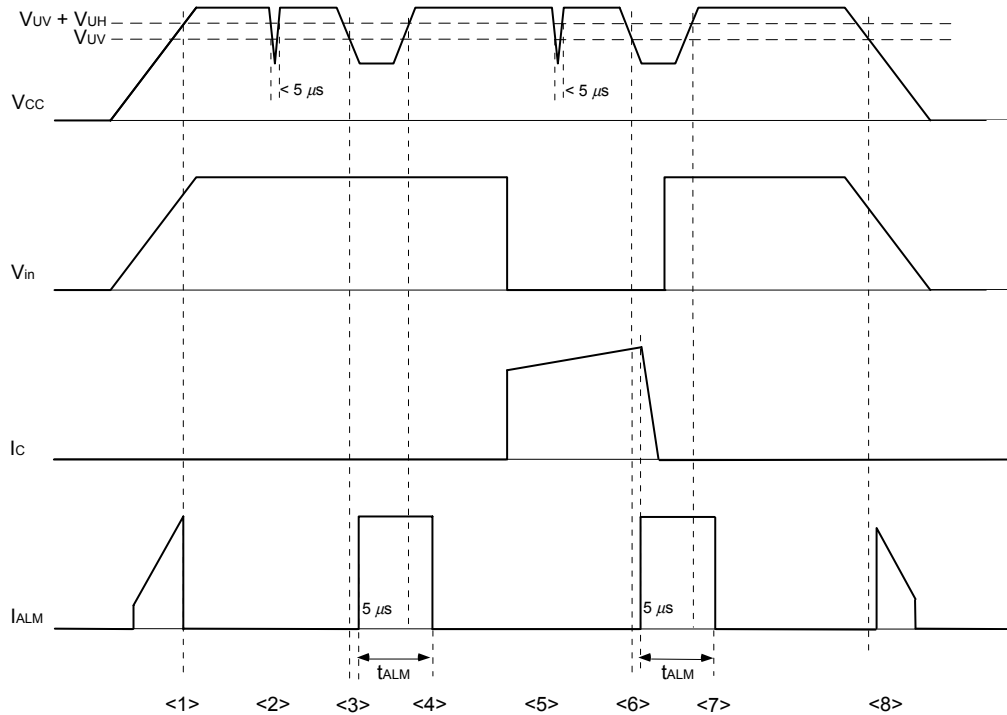

Fig. 3-15 Timing Chart UV (1)

Refer to Fig. 3-2 <3>.

- <1> If V_{CC} is below $V_{UV} + V_H$ while V_{CC} is ON, an alarm is output.
- <2> If the period in which V_{CC} falls below V_{UV} is shorter than $5 \mu s$, the protection function does not work (while V_{in} is OFF).
- <3> An alarm is output when a period of about $5 \mu s$ elapses after V_{CC} falls below V_{UV} if V_{in} is OFF, and IGBT remains OFF.
- <4> If V_{CC} returns to $V_{UV} + V_H$ after t_{ALM} elapses, UV is reset after t_{ALM} elapses if V_{in} is OFF and the alarm is also reset simultaneously.
- <5> If the period in which V_{CC} falls below V_{UV} is shorter than $5 \mu s$, the protection function does not work (while V_{in} is ON).
- <6> An alarm is output when a period of about $5 \mu s$ elapses after V_{CC} falls below V_{UV} if V_{in} is ON, and a soft IGBT shutdown occurs.
- <7> If V_{CC} returns to $V_{UV} + V_H$ after t_{ALM} elapses, UV is reset after t_{ALM} elapses if V_{in} is OFF and the alarm is also reset simultaneously.
- <8> An alarm is output if V_{CC} falls below V_{UV} while V_{CC} is OFF.

Undervoltage protection (UV) (2)

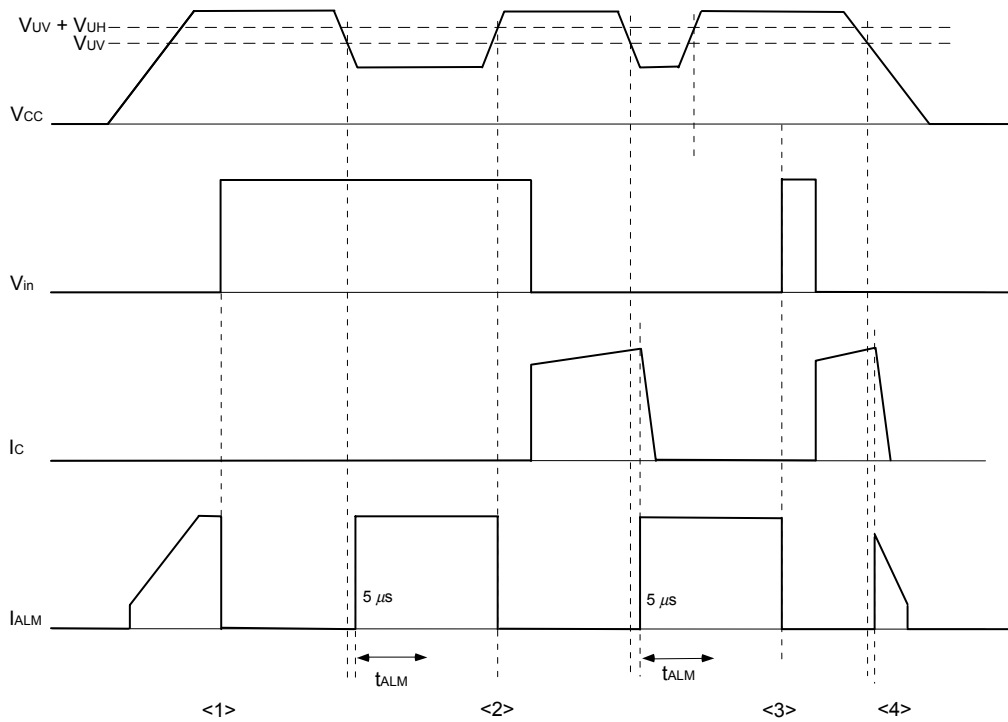

Fig. 3-16 Timing Chart UV (2)

Refer to Fig. 3-2 <3>.

- <1> If V_{CC} is below $V_{UV} + V_H$ while V_{CC} is ON, an alarm is output. (Until V_{in} changes to OFF)
- <2> If V_{CC} returns to $V_{UV} + V_H$ after t_{ALM} elapses, UV and the alarm are reset simultaneously with the return of $V_{UV} + V_H$ if V_{in} is OFF.
- <3> Even if V_{CC} returns to $V_{UV} + V_H$ after t_{ALM} elapses, UV is not reset after t_{ALM} elapses if V_{in} is ON. UV and the alarm are reset simultaneously with V_{in} OFF.
- <4> If V_{in} is ON while V_{CC} is OFF, the alarm is output, and a soft IGBT shutdown is executed while V_{CC} is below V_{UV} .

Overcurrent protection (OC)

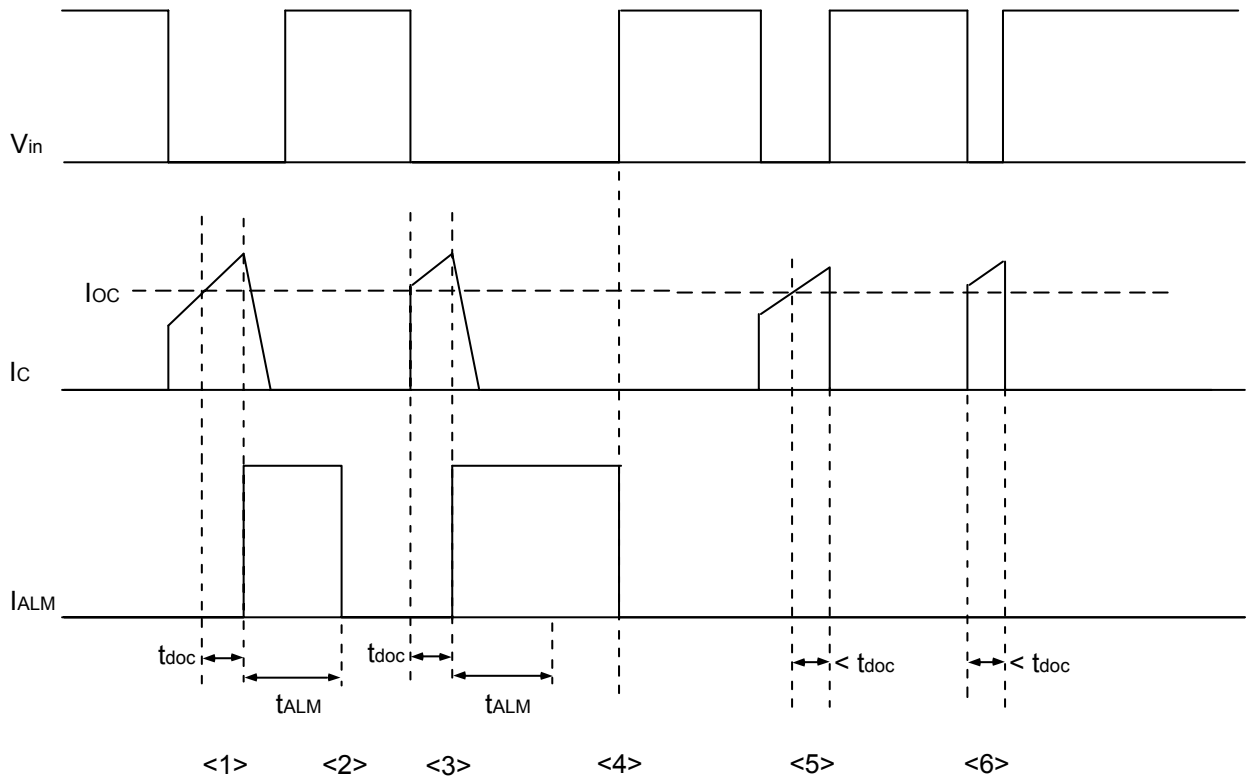

Fig. 3-17 Timing Chart OC

Refer to Fig. 3-2 <3>.

- <1> An alarm is output and a soft IGBT shutdown is executed when t_{DOC} elapses after I_c rises above I_{oc} .
- <2> OC and the alarm are reset simultaneously if V_{in} is OFF when t_{ALM} elapses.
- <3> An alarm is output and a soft IGBT shutdown is executed when t_{DOC} elapses after I_c rises above I_{oc} .
- <4> If V_{in} is ON when t_{ALM} elapses, OC is not reset. OC and the alarm are reset simultaneously when V_{in} is OFF.
- <5> If V_{in} changes to OFF before t_{DOC} elapses after I_c rises above I_{oc} , the protection function is not activated and a normal IGBT shutdown is executed.
- <6> If V_{in} changes to OFF before t_{DOC} elapses after I_c rises above I_{oc} , the protection function is not activated and a normal IGBT shutdown is executed.

Short-circuit protection

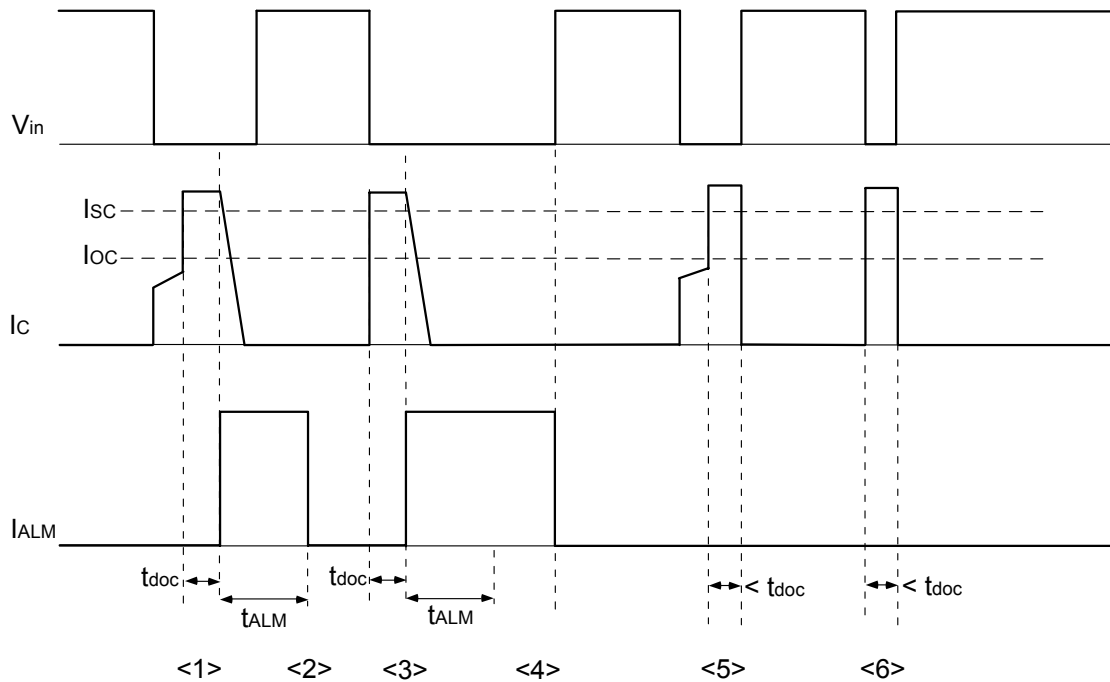

Fig. 3-18 Timing Chart SC

Refer to Fig. 3-2 <2>.

- <1> If the load shorts after I_c has started flowing and I_c exceeds I_{SC} , the I_c peak is suppressed instantly. An alarm is output and a soft IGBT shutdown is executed when t_{DOC} elapses.
- <2> OC and the alarm are reset simultaneously if V_{in} is OFF when t_{ALM} elapses.
- <3> If the load shorts and I_{SC} is exceeded simultaneously with the start of flow of I_c , the I_c peak is instantly suppressed. An alarm is output and a soft IGBT shutdown is executed after t_{DOC} elapses.
- <4> If V_{in} is ON when t_{ALM} elapses, OC is not reset. OC and the alarm are reset simultaneously when V_{in} is OFF.
- <5> If the load shorts after I_c has started flowing and I_c exceeds I_{SC} , the I_c peak is suppressed instantly. Then, if V_{in} changes to OFF before t_{DOC} elapses, the protection function is not activated and a normal IGBT shutdown occurs.
- <6> If the load shorts simultaneously with the start of flow of I_c and I_c exceeds I_{SC} , the I_c peak is suppressed instantly. Then, if V_{in} changes to OFF before t_{DOC} elapses, the protection function is not activated and a normal IGBT shutdown is executed.

Case temperature overheating protection (TcOH)

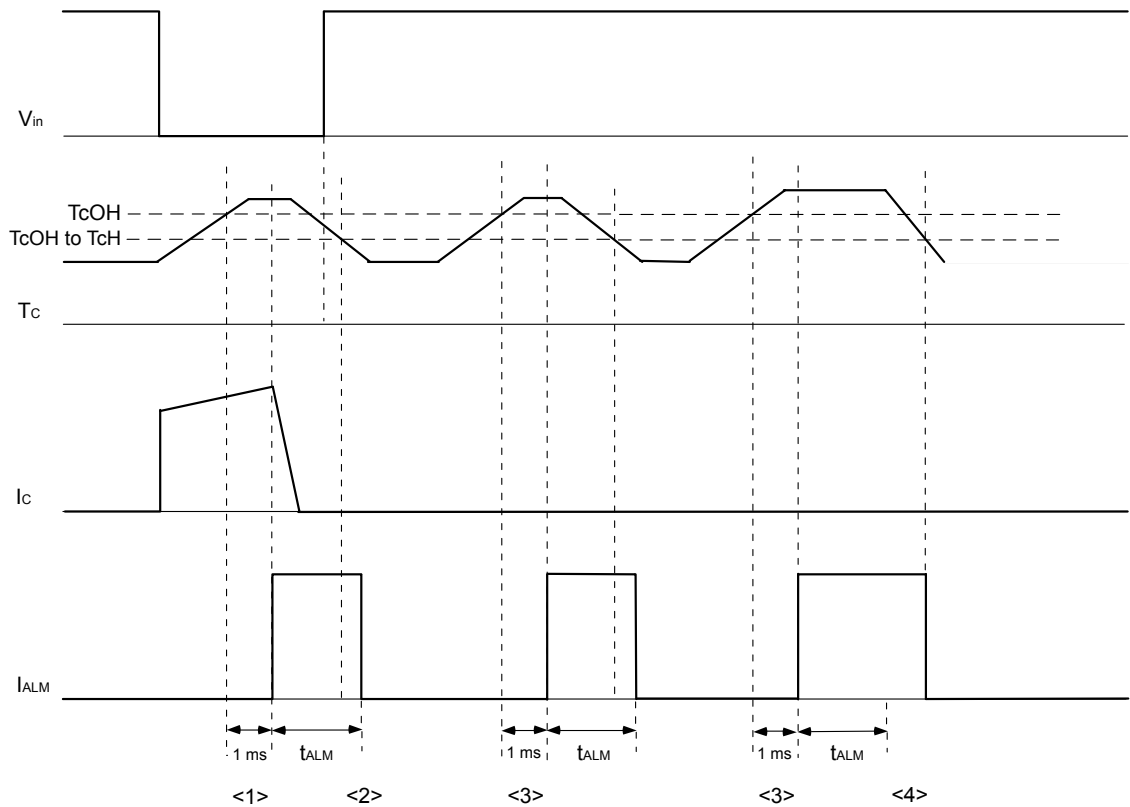

Fig. 3-19 Timing Chart TcOH

Refer to Fig. 3-2 <4>.

- <1> An alarm is output if the case temperature T_c continuously exceeds T_{COH} for a period of about 1 ms, and if V_{in} is ON, a soft shutdown of all IGBTs on the lower arm side is executed.
- <2> If T_c falls below $T_{COH}-T_{CH}$ before t_{ALM} elapses, the alarm is reset when t_{ALM} elapses.
- <3> If T_c exceeds continuously T_{COH} for a period of about 1 ms, an alarm is output. (While V_{in} is OFF)
- <4> If T_c has not fallen below $T_{COH}-T_{CH}$ when t_{ALM} elapses, the alarm is not reset. When T_c falls below $T_{COH}-T_{CH}$ after t_{ALM} elapses, the alarm is reset.

IGBT chip overheating protection (TjOH) (1)

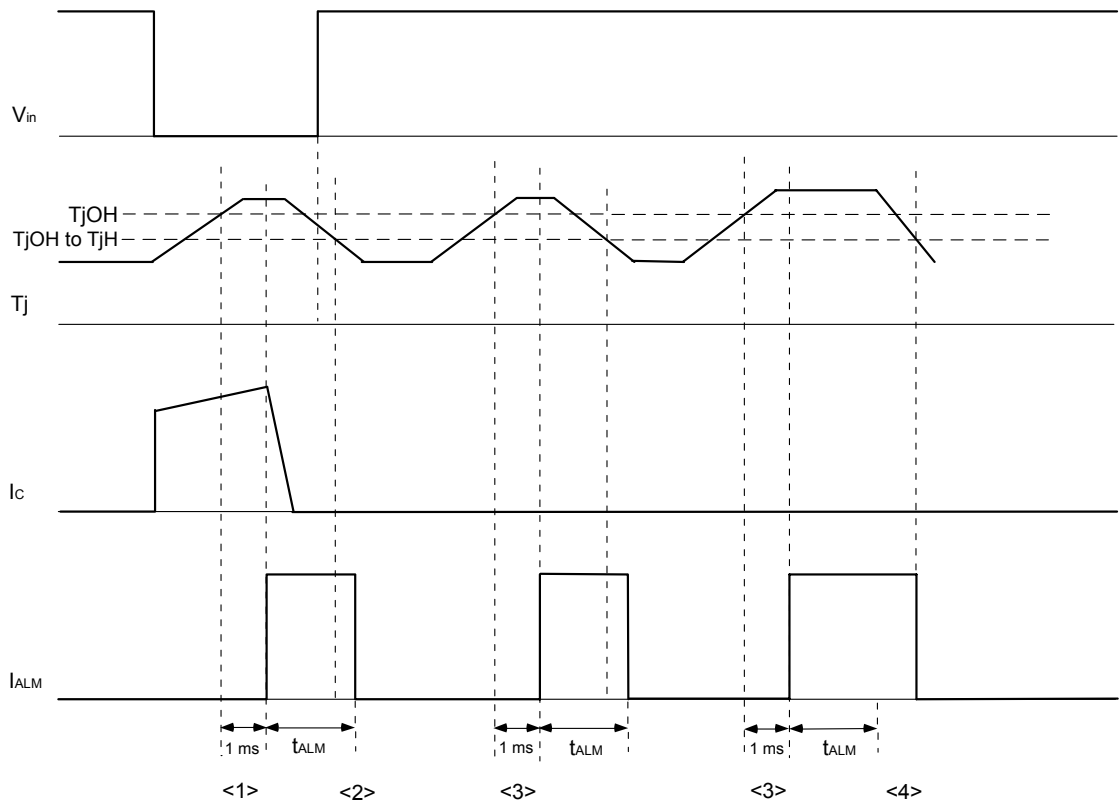

Fig. 3-20 Timing chart TjOH (1)

Refer to Fig. 3-2 <4>.

- <1> An alarm is output and a soft IGBT shutdown is executed if the IGBT chip temperature T_j continuously exceeds T_{jOH} for a period of about 1 ms.
- <2> If T_j falls below $T_{jOH} - T_{jH}$ before t_{ALM} elapses, OH and the alarm are simultaneously reset if V_{in} is OFF when t_{ALM} elapses.
- <3> An alarm is output if T_j continuously exceeds T_{jOH} for a period of about 1 ms, and if V_{in} is OFF, the protection function is not activated.
- <4> When T_j falls below $T_{jOH} - T_{jH}$ after t_{ALM} elapses, OH and the alarm are reset simultaneously if V_{in} is OFF.

IGBT chip overheating protection (TjOH) (2)

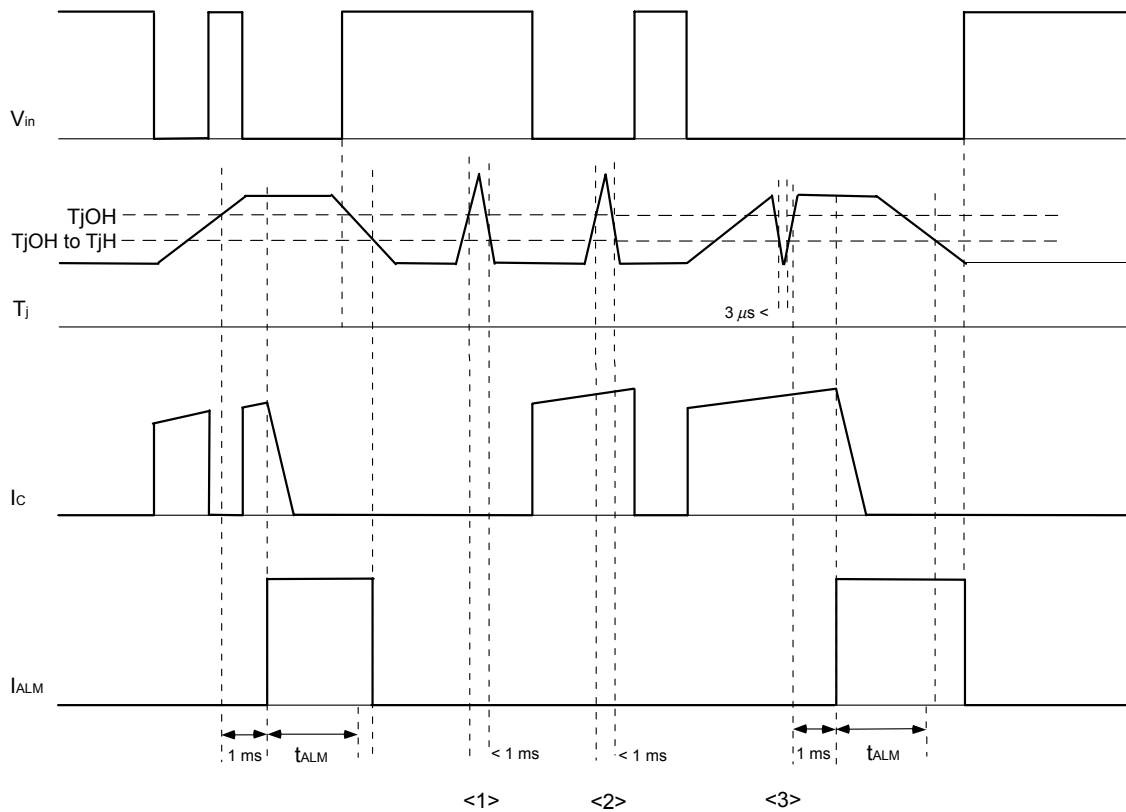

Fig. 3-21 Timing Chart TjOH (2)

Refer to Fig. 3-2.

- <1> If T_j exceeds T_{jOH} and then falls below T_{jOH} within about 1 ms, OH does not operate regardless of whether V_{in} is ON or OFF.
- <2> If T_j exceeds T_{jOH} and then falls below T_{jOH} within about 1 ms, OH does not operate regardless of whether V_{in} is ON or OFF.
- <3> If T_j exceeds T_{jOH} and then falls below T_{jOH} for a period of about 3 μs or longer, the 1 ms detection timer is reset.

Chapter 4

Examples of Application Circuits

Contents	Page
1. Examples of Application Circuits.....	4-2
2. Precautions	4-7
3. Photocoupler and Peripheral Circuits	4-10
4. Connectors	4-11

Fig. 4-2 shows an example of an application circuit for P610, P611, and P612 (types without brake).

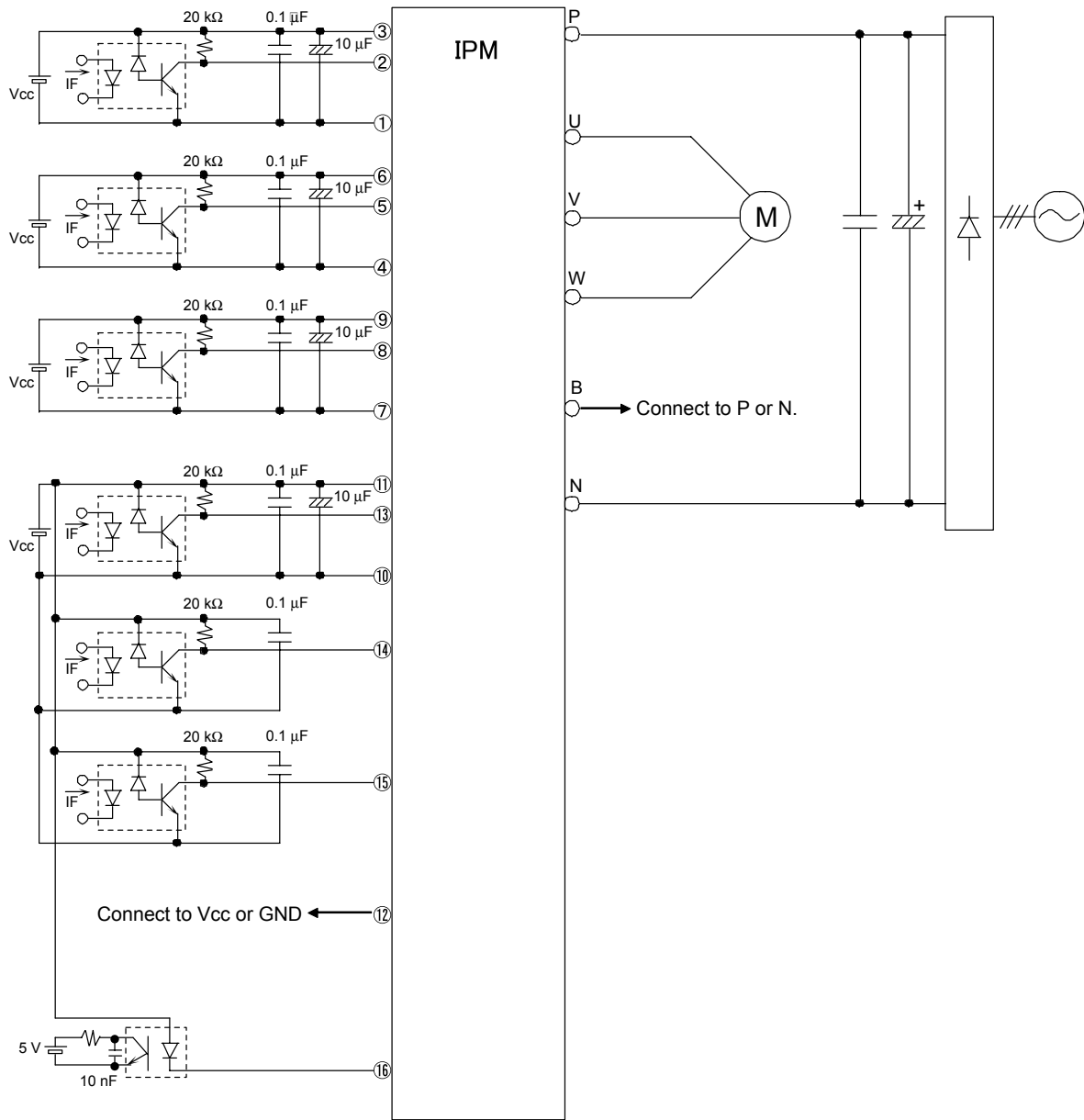

Fig. 4-2 Example of Application Circuit for P610, P611, and P612 (Types Without Brake)

Fig. 4-3 shows an example of an application circuit for P621 and P622 (types with built-in brake).

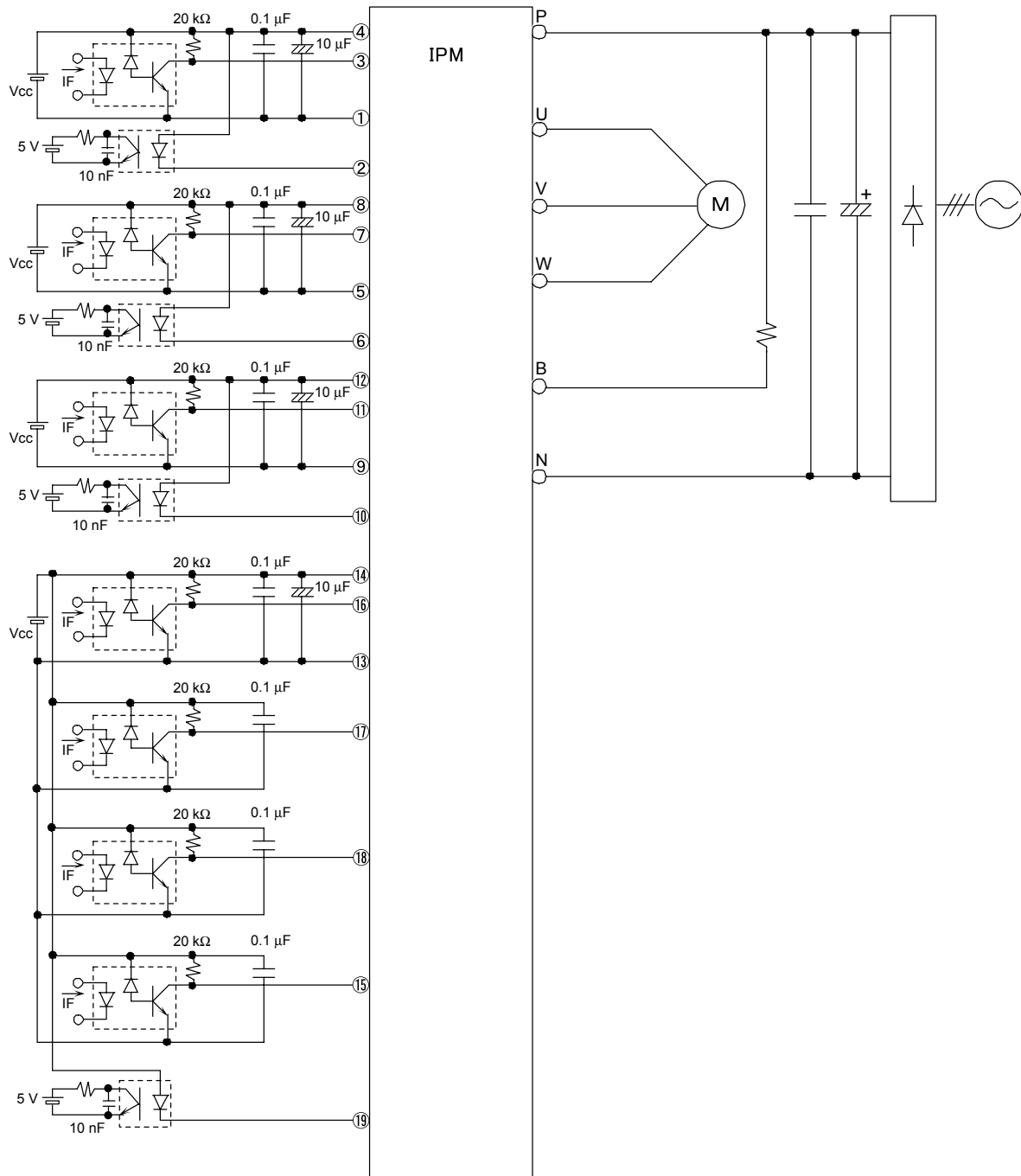

Fig. 4-3 Example of Application Circuit for P621, P622 (with Upper Arm Alarm)
(Types with Built-in Brake)

Fig. 4-4 shows an example of an application circuit for P621 and P622 (types without brake).

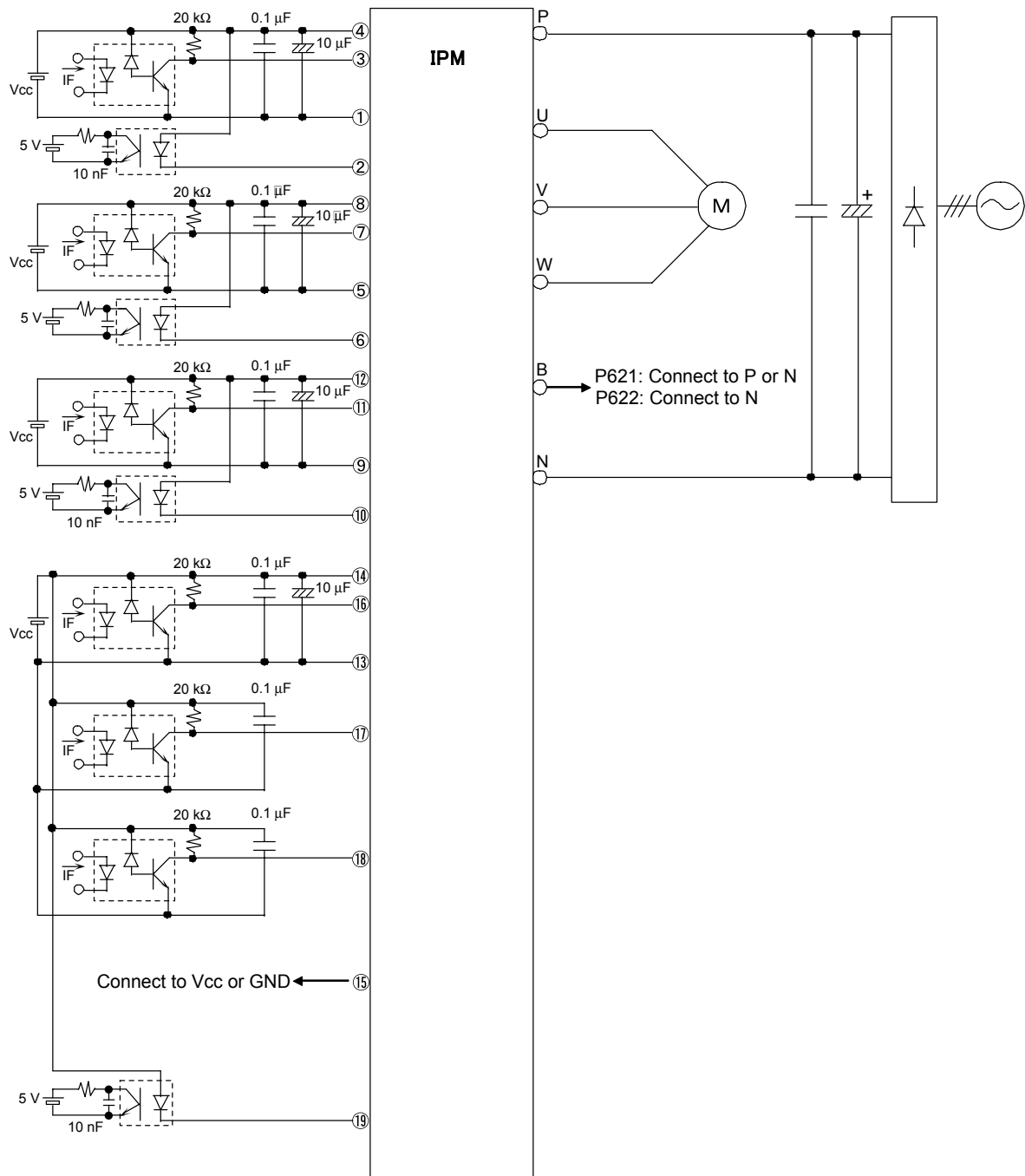

Fig. 4-4 Example of Application Circuit for P621, P622 (with Upper Arm Alarm) (Types Without Brake)

Fig. 4-5 shows an example of an application circuit for P617.

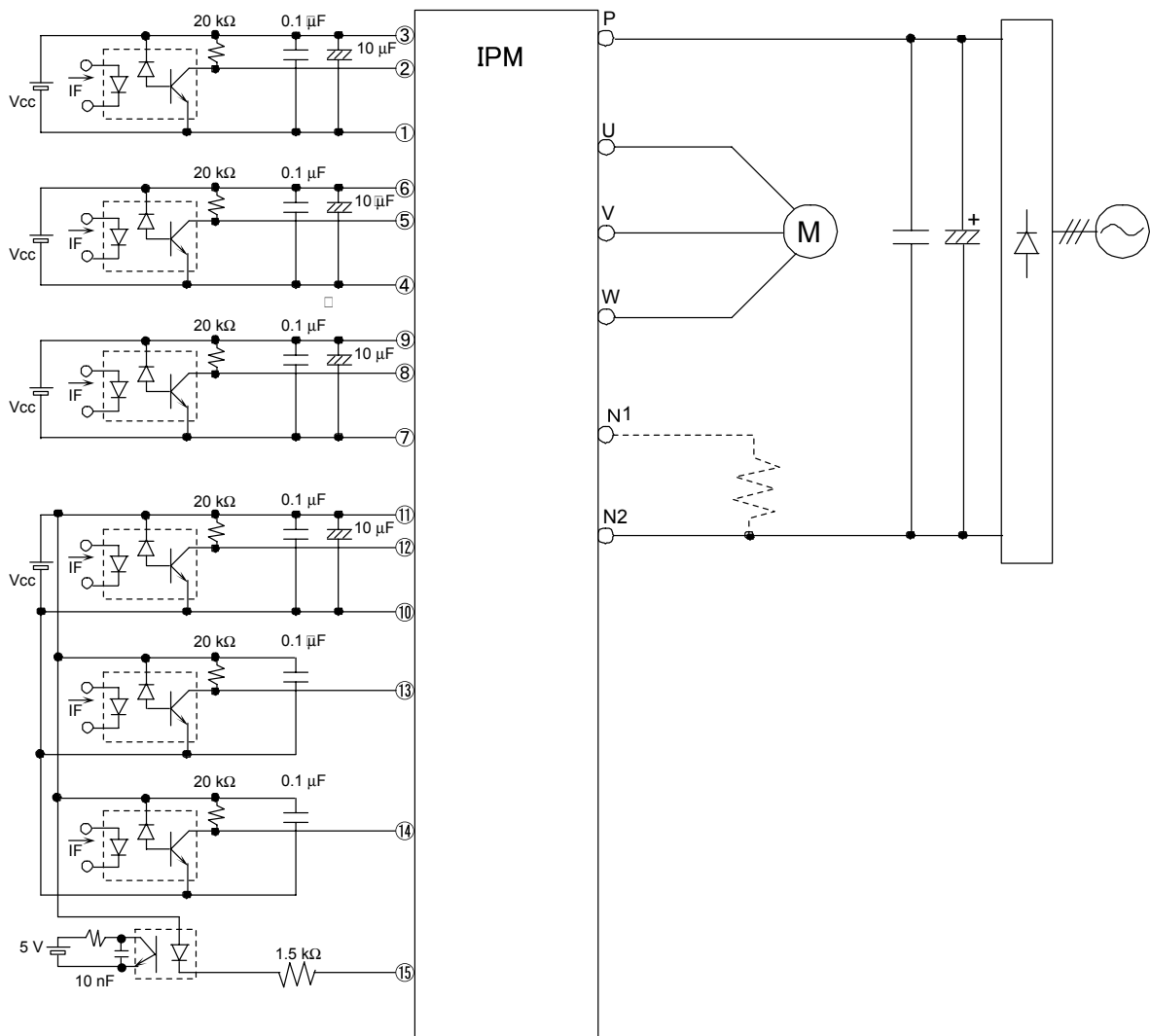

Fig. 4-5 Example of Application Circuit for Small-capacity IPM P617

Fig. 4-6 shows an example of an application circuit for P619.

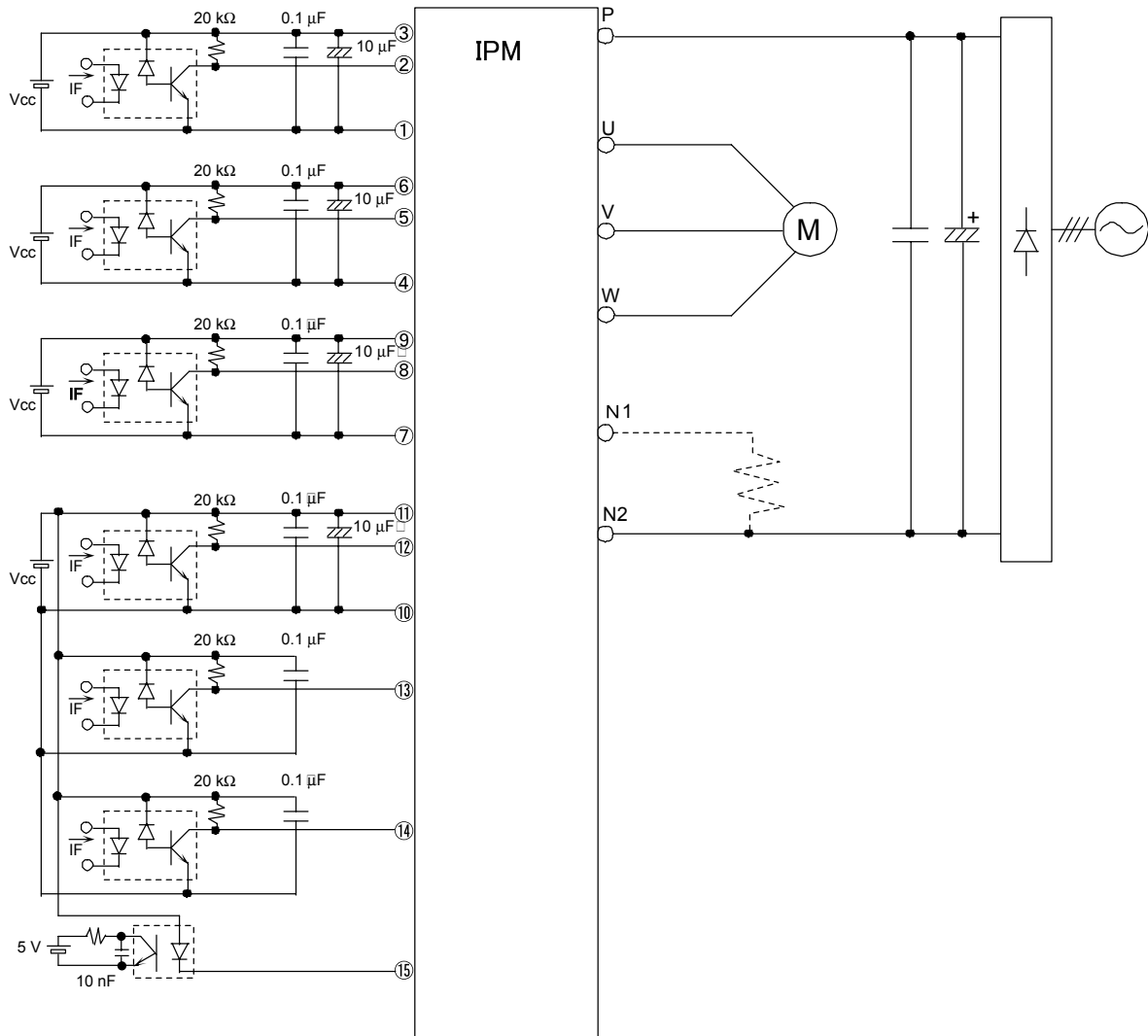

Fig. 4-6 Example of Application Circuit for Small-capacity IPM P619

2 Precautions

2.1 Control power source

As shown in the application circuit examples, a total of four isolation power sources are required for the control power sources, 3 on the upper arm side and 1 on the lower arm side.

If you are using commercial power source units, do not connect the GND terminal on the side of the power source output.

When the GND on the output side is connected to + or -, faulty operation occurs because each power source is connected to the ground on the side of power source input. Stray capacity between each power source and ground should be reduced to a minimum.

2.2 Structural isolation among four power sources (input connectors and PC boards)

Isolation is needed between each of the four power sources and the main power source.

Since a large amount of dv/dt is applied to this isolation during IGBT switching, keep sufficient clearance between the components and the isolation. (2 mm or more is recommended.)

2.3 GND connection

The control power source GND on the lower arm side and the main power source GND are connected inside the IPM. Never connect them outside the IPM. If you connect them outside the IPM, loop currents generated inside and outside the IPM flow to the lower arm due to di/dt and cause malfunctioning of the photocoupler and the IPM. The input circuit of the IPM may also be damaged.

2.4 Control power source capacitor

The 10 μF and 0.1 μF capacitors connected to each control power source as shown in the application circuit examples are not intended for smoothing the control power sources, but for compensating the wiring impedance up to the IPM. Capacitors for smoothing are needed separately.

Since transient variations may be caused in the wiring impedance from the capacitor to the control circuit, connect the capacitor as close to the IPM control terminal and photocoupler pin as possible.

Select capacitors with lower impedance and better frequency characteristics for the electrolytic capacitors. In addition, connect capacitors with better frequency characteristics, such as film capacitors, in parallel.

2.5 Alarm circuits

- The potential on the secondary side of the alarm photocoupler may vary due to dv/dt . It is recommended to stabilize the potential by connecting a capacitor of approximately 10 nF.
- As P617 does not have a built-in alarm resistor, a resistor of 1.5 k Ω must be connected on the outside of the IPM.

2.6 Pull-up of the signal input terminal

Pull up the control signal input terminal to V_{cc} with a resistor of 20 k Ω . Even if you do not use the brake in the built-in brake IPM, still pull up the DB input terminal. If you do not pull up the terminal, a malfunction may be caused by dv/dt .

2.7 Snubber

Connect the snubber to the PN terminals directly. For the P612 package set up the snubber for each PN terminal on both sides.

2.8 B terminal

In the case of the 6 in 1 package (without brake) type, connecting the B terminal to the N or P terminal as described below is recommended.

P610, P611, P612, P621N or P terminal

P622(Econo-IPM)N terminal (connection to the P terminal causes an internal short-circuit)

2.9 Upper arm alarm

When the upper arm alarm of an IPM with upper arm alarm output is not used, connect the alarm terminal to Vcc to stabilize the potential.

2.10 Overcurrent protection for small-capacity IPMs

The limit level for overcurrent protection can be adjusted to a high level by adding a resistor between the N1 and N2 terminals of small-capacity IPMs (P617, 619). The resistor added at that time must be mounted close to the N1 and N2 terminals. A long distance from the N1 and N2 terminals can cause faulty operation of the IPM.

2.11 IPM input circuit

The constant-current circuit shown in Fig. 4-7 is provided in the input section of our IPMs, and outflow from the IPM takes place at the timing shown in the figure. For this reason, the IF on the primary side of the photocoupler must be determined so that a current of $I_R + 1\text{ mA}$ flows through the pull-up resistor on the secondary side of the photocoupler. If the IF is not sufficient, faulty operation on the secondary side is possible.

Also, the pull-up resistor must be selected so that a current of $I_R + 1\text{ mA}$ flows on the secondary side of the photocoupler when the photocoupler is ON and that the current flowing into the IPM at the time of OFF does not exceed the $I_{in\text{ MAX}}$ listed in the specifications.

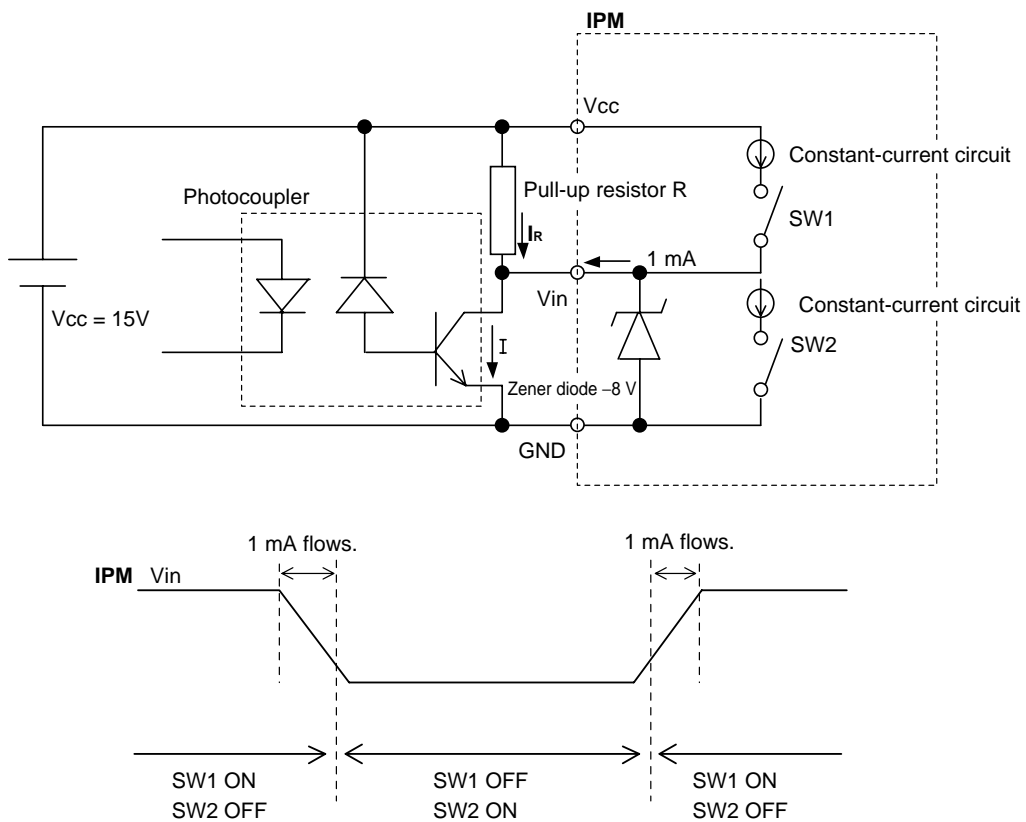

Fig. 4-7 IPM Input Circuit and Rated Current Operation Timing

3 Photocoupler and Peripheral Circuits

3.1 Photocoupler for control input

- Photocoupler rating

Use a photocoupler satisfying the following characteristics.

- $CMH = CML > 15 \text{ kV}/\mu\text{s}$ or $10 \text{ kV}/\mu\text{s}$
- $tpHL = tpLH < 0.8 \mu\text{s}$
- $tpLH - tpHL = -0.4$ to $0.9 \mu\text{s}$
- $CTR > 15\%$

Example: Product of Agilent: HCPL-4504

Product of Toshiba: TLP759 (IGM)

Note: Safety standards such as UL and VDE should also be applied.

- Wiring between photocoupler and IPM

Make the wiring between the photocoupler and the IPM as short as possible to reduce the wiring impedance between the photocoupler and the IPM control terminal. Separate each wire between the primary and secondary circuits so that floating capacitance does not become large, since a strong dv/dt is applied between the primary and secondary circuits.

- Light emitting diode driving circuit

The dv/dt withstand capability of the photocoupler is also affected by the input light emitting diode driving circuit. A driving circuit example is shown in Fig. 4-8.

Good example: Totempole output IC

Current limiting resistor on the cathode side of the photo diode

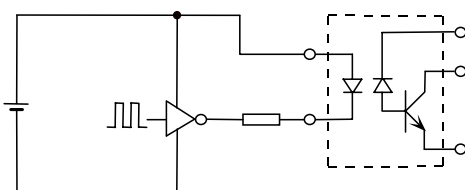

Bad example: Open collector

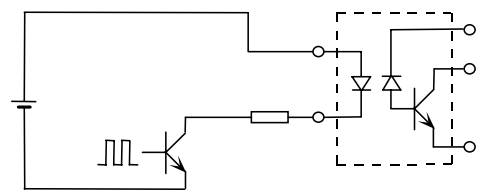

Good example: Photo diode A-K is shorted by transistors C-E (example which is particularly fit for photocoupler OFF)

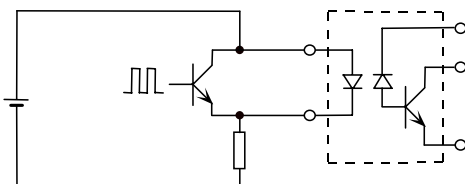

Bad example: Current limiting resistor on the anode side of the photo diode

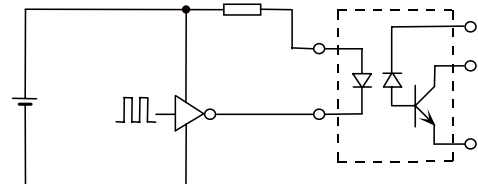

Fig. 4-8 Photocoupler Input Circuits

3.2 Photocoupler for alarm output

- Photocoupler rating

General-purpose photocouplers can be used, but photocouplers satisfying the following characteristics are recommended.

- $100\% < \text{CTR} < 300\%$
- Single-element type

Example: TLP521-1-GR rank

Note: Safety standards such as UL and VDE should also be applied.

- Input current limiting resistor

A current limiting resistor for the light emitting diode in the photocoupler input is included in the IPM.

$R_{\text{ALM}} = 1.5 \text{ k}\Omega$ and if connected directly to V_{CC} , about 10 mA of I_{F} flows with $V_{\text{CC}} = 15 \text{ V}$.

Therefore, there is no need to connect any current limiting resistor.

However, if a large amount of current, i.e., $I_{\text{out}} > 10 \text{ mA}$, is needed on the photocoupler output, increase the CTR value of the photocoupler to the required value.

- Wiring between the photocoupler and the IPM

Since a large amount of dv/dt is also applied on the photocoupler for the alarm, the same precautions as described in 3.1 should be taken.

4 Connectors

Connectors suitable for the shape of the R-IPM control terminals are commercially available.

16-pin connector for P610, 611, 612: MDF7-25S-2.54DSA made by Hirose Electric

For P621: DF10-31S-2DSA made by Hirose Electric

Please confirm the reliability and the specifications of the above connectors with the manufacturer.

Chapter 5

Cooling Design

Contents	Page
1. Cooler (Heat Sink) Selection Method	5-2
2. Notes on Heat Sink Selection	5-2

1 Cooler (Heat Sink) Selection Method

- To safeguard operation of the IGBT, make sure the junction temperature T_j does not exceed T_{jmax} . Cooling should be designed in such a way that ensures that T_j is always below T_{jmax} even in abnormal states such as overload operation as well as under the rated load.
- Operation of IGBT at temperatures higher than T_{jmax} could result in damage to the chips. In the IPM, the T_{jOH} protection function operates when the chip temperature of IGBT exceeds T_{jmax} . However, if the temperature rises too quickly, the chip may not be protected.
- Likewise, note that the chip temperature of FWD should not exceed T_{jmax} .
- When selecting the cooler (heat sink), always measure the temperature directly under the center of the chip. The Econo IPM series in particular is designed with operational preconditions for servo applications, etc., in which the temperature increases/decreases in a short time, so care is required in regard to heat accumulation when using under other conditions. As the structure and design place special importance upon compactness, there is a tendency for heat to accumulate in the power chip located at the center. For the chip layout, refer to the IPM internal structure drawing: MT6M5313. For the concrete design, refer to the following document.

“IGBT MODULE APPLICATION MANUAL REH984”

- Contents:
- Power dissipation loss calculation
 - Selecting heat sinks
 - Heat sink mounting precautions
 - Troubleshooting

2 Notes on Heat Sink Selection

How to select heat sinks is described in the manual REH982. Note also the following points.

- Flatness of the heat sink surface

Flatness between mounting screw pitches: 0 to +100 μm , roughness: 10 μm or less

If the heat sink surface is concave, a gap occurs between the heat sink and the IPM, leading to deterioration of cooling efficiency.

If the flatness is +100 μm or more, the copper base of the IPM is deformed and cracks could occur in the internal isolating substrates.

Chapter 6

Cautions on Use

Contents	Page
1. Main Power Source	6-2
2. Control Power Source	6-3
3. Protection Functions	6-4
4. Power Cycling Capability	6-6
5. Other	6-6

1 Main Power Source

1.1 Voltage range

1.1.1 600 V system IPMs

- The main power source should not exceed 500 V (= $V_{DC}(\text{surge})$) between the P and N main terminals. The voltage between the collector and emitter main terminals (= V_{CES}) should not exceed 600 V (= absolute max. rated voltage).
- Surge voltage occurs in the wiring inductance inside the IPM due to di/dt during switching, but the product is designed so that 600 V is not exceeded between the collector and emitter main terminals when the main power source is used at $V_{DC}(\text{surge})$ or lower between the P and N main terminals.
- In order for the maximum surge voltage at the time of switching not to exceed the rated voltage, keep the connecting wires between the IPM and the embedded product short and install a snubber close to the P and N terminals.

1.1.2 1200 V system IPMs

- The main power source should not exceed 1000 V (= $V_{DC}(\text{surge})$) between the P and N main terminals. The voltage between the collector and emitter main terminals (= V_{CES}) should not exceed 1200 V (= absolute max. rated voltage).
- Surge voltage occurs in the wiring inductance inside the IPM due to di/dt during switching, but the product is designed so that 1200 V is not exceeded close to the chip when the main power source is used at $V_{DC}(\text{surge})$ or lower between the P and N main terminals.
- In order for the maximum surge voltage at the time of switching not to exceed the rated voltage, keep the connecting wires between the IPM and the embedded product short and install a snubber close to the P and N terminals.

1.2 External noise

Countermeasures have been taken against external noise within the IPM, but faulty operation may possibly occur depending on the type and intensity of the noise.

Please take sufficient countermeasures against noise entering the IPM.

1.2.1 Noise from outside the equipment

- Apply a noise filter on the AC line, isolate the ground and so on.
- When required, add capacitors of 100 pF or less between all phase signal inputs and signal GND.
- Install arresters against lightning surges, etc.

1.2.2 Noise from within the equipment

- Outside the rectifier: Implement the same countermeasures as the above.
- Inside the rectifier: Apply snubber circuits on the PN lines.
(In case of multiple inverters connected to one rectifier converter, etc.)

1.2.3 Noise from the output terminals

- Take external countermeasures so that contactor switching surges and so on do not enter.

2 Control Power Source

2.1 Voltage range

- The drive circuit shows stable operation when the control power source voltage is in the range of 13.5 to 16.5 V.
Operation with a value as close to 15 V as possible is recommended.
- When the control power source voltage is below 13.5 V, the loss will increase and noise will show a tendency to decrease.
Also, the protection performance will shift, so that the protection functions may not be sufficient and chip damage may occur.
- When the control power source voltage drops below 13.5 V, dropping down to VUV or lower, the undervoltage protection function (UV) operates.
When the control power source voltage recovers to VUV + VH, UV is automatically released.
- When the control power source voltage exceeds 16.5 V, the loss decreases and noise shows a tendency to increase.
Also, the protection performance will shift, so that the protection functions may not be sufficient and chip damage may occur.
- When the control power source voltage is below 0 V (reverse bias) or exceeds 20 V, the drive circuit and/or the main chip may be damaged. Never apply these voltages.

2.2 Voltage ripple

- The recommended voltage range of 13.5 to 16.5 V includes the voltage ripple of Vcc.
During the manufacture of the control power source, be sure to keep the voltage ripple sufficiently low.
Also be sure to keep noise superimposed on the power source sufficiently low.
- Design the control power source so as to keep dv/dt at 5 V/μs or lower.

2.3 Power source start-up sequence

- Apply the main power source after confirming that Vcc is in the recommended voltage range.
If the main power source is applied before the recommended voltage is reached, the chip may be destroyed (worst-case scenario).

2.4 Alarm at the time of power source start-up and shutdown

- At the time of power source start-up, an alarm is output at the UV protection function operation level voltage.

Recovery is made when the protection release level voltage is reached, but as the alarm will not be released as long as an ON signal is input, appropriate measures must be taken on the drive circuit side.

- As there is also alarm output at the time of power source shutdown, similar measures are required.

2.5 Precautions upon control circuit design

- Design with sufficient margin, taking the current consumption specification (I_{cc}) for the drive circuit into consideration.
- Make the wiring between the input terminals of the IPM and the photocoupler as short as possible, and use a pattern layout with a small stray capacitance for the primary side and the secondary side of the photocoupler.
- Install a capacitor as close as possible between V_{cc} and GND in the case of a high-speed photocoupler.
- For a high-speed photocoupler, use a high CMR type in which $t_{pHL}, t_{pLH} \leq 0.8 \mu s$.
- For the alarm output circuit, use a low-speed photocoupler type in which $CTR \geq 100\%$.
- Use four isolated power sources for the control power source V_{cc} . Also use a design with suppressed voltage fluctuations.
- When a capacitor is connected between the input terminals and GND, note that the response time in regard to an input signal on the primary side of the photocoupler becomes longer.
- Design the primary-side current of the photocoupler with sufficient margin taking the CTR of the photocoupler being used into consideration.

3 Protection Functions

As the built-in protection functions and the presence or absence of alarm output differ according to the package and the model, confirm the protection functions of your IPM referring to the "List of IPM built-in functions" in chapter 3.

3.1 Protection operations in general

3.1.1 Range of protection

- The protection functions included in the IPM are designed for non-repetitive abnormal phenomena.
- Do not apply constant stress that exceeds the rating.

3.1.2 Countermeasures for alarm output

- If an alarm is output, stop the input signal into the IPM immediately to stop the equipment.
- The IPM protection functions protect against abnormal phenomena, but they cannot remove the causes of the abnormalities. After stopping the equipment, restart it after you have removed the cause of the abnormality.

3.2 Precautions for the protection functions

3.2.1 Overcurrent

- The overcurrent protection function (OC) executes a soft shutdown of the IGBT and outputs an alarm when the overcurrent continues in excess of the insensitive time (tdoc).
Accordingly, OC does not operate when the overcurrent is removed within the tdoc period.
- In P619, the current is detected on the N-line, so there is no OC for the upper arm.

3.2.2 Starting with load short-circuit

- The OC has an insensitive time (tdoc) of approximately 5 to 10 μ s. If the input signal pulse width is shorter than this, the OC does not operate.
- If an input signal pulse width of tdoc or less continues when starting with the load shorted, short circuits occur continuously and the chip temperature of the IGBT rises rapidly.
In such a case, the rise of the case temperature does not follow the rise of the chip temperature and the case temperature overheating protection function (TcOH) does not operate. Normally the chip temperature overheating protection function (TjOH) operates and provides protection, but as TjOH also has a delay of approximately 1 ms, depending on the state of the chip temperature rise, the protection operation may not occur in time, possibly causing damage to the chip.

3.2.3 Ground short

- If a ground short occurs and an overcurrent flows through the lower arm of the IGBT, overcurrent protection by OC occurs for all IPMs.
- If a ground short occurs and an overcurrent flows through the upper arm of the IGBT, the protection operation differs according to the package and the model.

P621, P622

Overcurrent protection is provided by the OC of the upper arm. Alarm output also is provided.

P610, P611, P612

Overcurrent protection is provided by the OC of the upper arm, but there is no alarm output.

For details, refer to the related document MT6M3046 "Protection in R-IPM Earth Fault Mode".

P619, P617

As there is no OC for the upper arm, there is no overcurrent protection and no alarm output.

3.3 FWD overcurrent protection

- FWD current is not detected. Accordingly, there is no protection when overcurrent flows only for FWD.

3.4 Case temperature protection

- TcOH is the protection function used when the temperature of the entire insulation substrate rises. Accordingly, the chip temperature protection function (TjOH) operates when the heating is concentrated on one chip.

3.5 Chip temperature protection

- A chip temperature protection function (T_{jOH}) is built into all IGBTs, including the brake part.

4 Power Cycling Capability

The lifetime of semiconductor products is not eternal. Accumulated fatigue by thermal stress resulting from rising and falling temperatures generated within the device may shorten the lifetime of the components. Narrow the range of temperature variations as much as possible.

5 Other

5.1 Precautions for usage and installation into equipment

- (1) Also read the IPM delivery specifications for IPM use and installation into the device.
- (2) Always prevent secondary damage by installing a fuse or a circuit breaker with a suitable capacity between the commercial power source and this product, keeping in mind the possibility of chip damage caused by unexpected accidents.
- (3) When investigating the chip duty at the time of a normal turn-off operation, make sure that the operation track for the turn-off voltage and current is within the RBSOA specifications.
When investigating the chip duty with non-repetitive short-circuit interruption, make sure that it is within the SCSOA specifications.
- (4) Use this product upon full understanding of the product usage environment and upon investigation of whether the product reliability life is satisfactory or not. In case of use in excess of the reliability life of the product, the chip may be destroyed before the target life of the device.
- (5) Apply a thermal compound or the like between the IPM and the heat sink to make the contact heat resistance as small as possible.
- (6) Use the IPM within the range specified in the specifications for the screw torque and the heat sink flatness.
Incorrect handling can cause insulation failure.
- (7) Take care so that no load is placed on the IPM. Particularly, the control terminal should not be bent.
- (8) Do not perform soldering by reflow on the main terminal and control terminal. Take care to prevent any effect on the IPM by heat, flux, and washing solutions used for soldering other components.
- (9) Avoid locations where corrosive gases are generated or dust is present.
- (10) Take care to prevent high-voltage static electricity entering the main terminal and control terminal.
- (11) When removing and attaching the control circuit and the IPM, first confirm that V_{cc} is 0 V.

Chapter 7

Trouble Shooting

Contents	Page
1. Troubleshooting	7-2
2. Fault Analysis Diagrams	7-2
3. Alarm Cause Analysis Diagram	7-8

1 Trouble Shooting

In comparison to standard modules, IPMs have various protection functions (overcurrent, overheating, etc.) built in, so that their devices are not easily destroyed by abnormal conditions. However, destruction may occur depending on the abnormality, so that countermeasures are required once the cause and state of occurrence have been clarified. An analysis diagram indicating the cause of destruction is shown on page 2 and should be used to investigate the causes of destruction.

(For element fault judgment, refer to the Module Application Manual, chapter 4, item 2 "Fault Judgment Method".)

Also, in the case of alarm output from the IPM, use the alarm cause analysis diagrams of Fig. 7-2 to investigate the cause.

2 Fault Analysis Diagrams

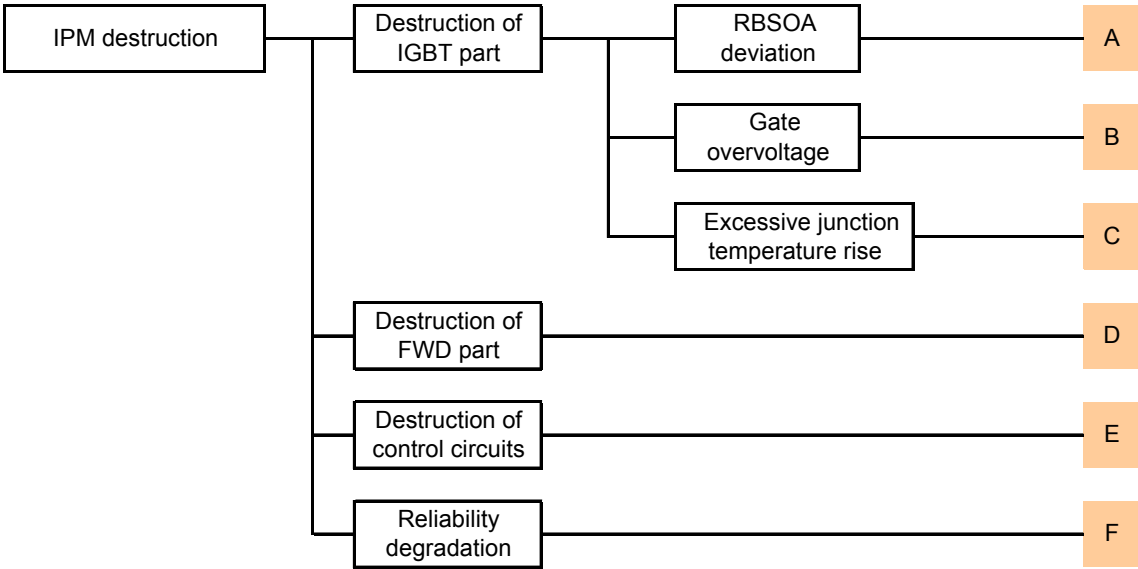

Fig. 7-1 (a.) IPM Fault Analysis Diagram (The letters A to F connect to the following diagrams.)

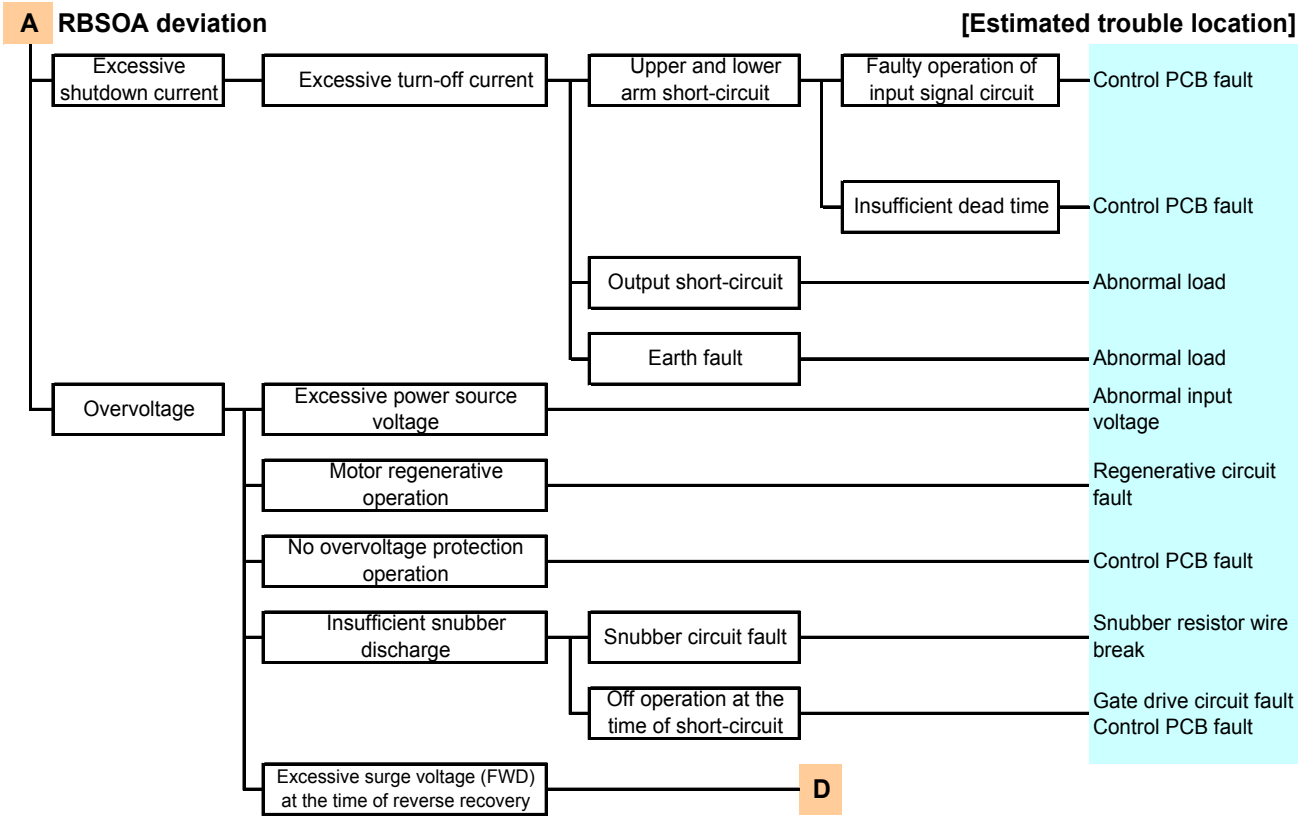

Fig. 7-1 (b) Mode A: RBSOA Deviation

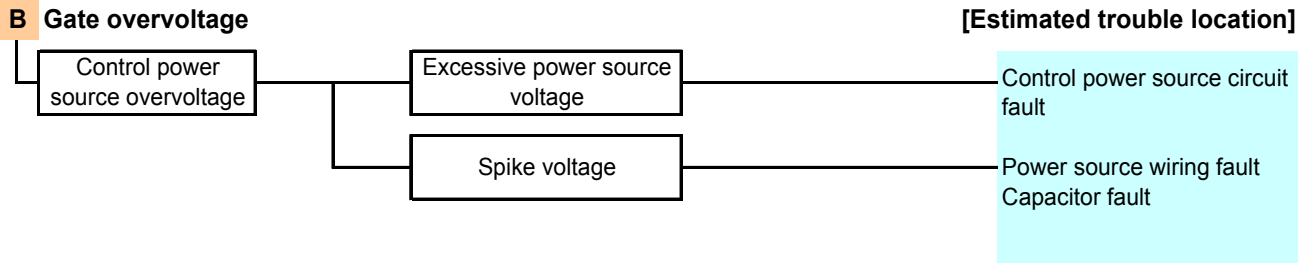

Fig. 7-1 (c) Mode B: Gate Overvoltage

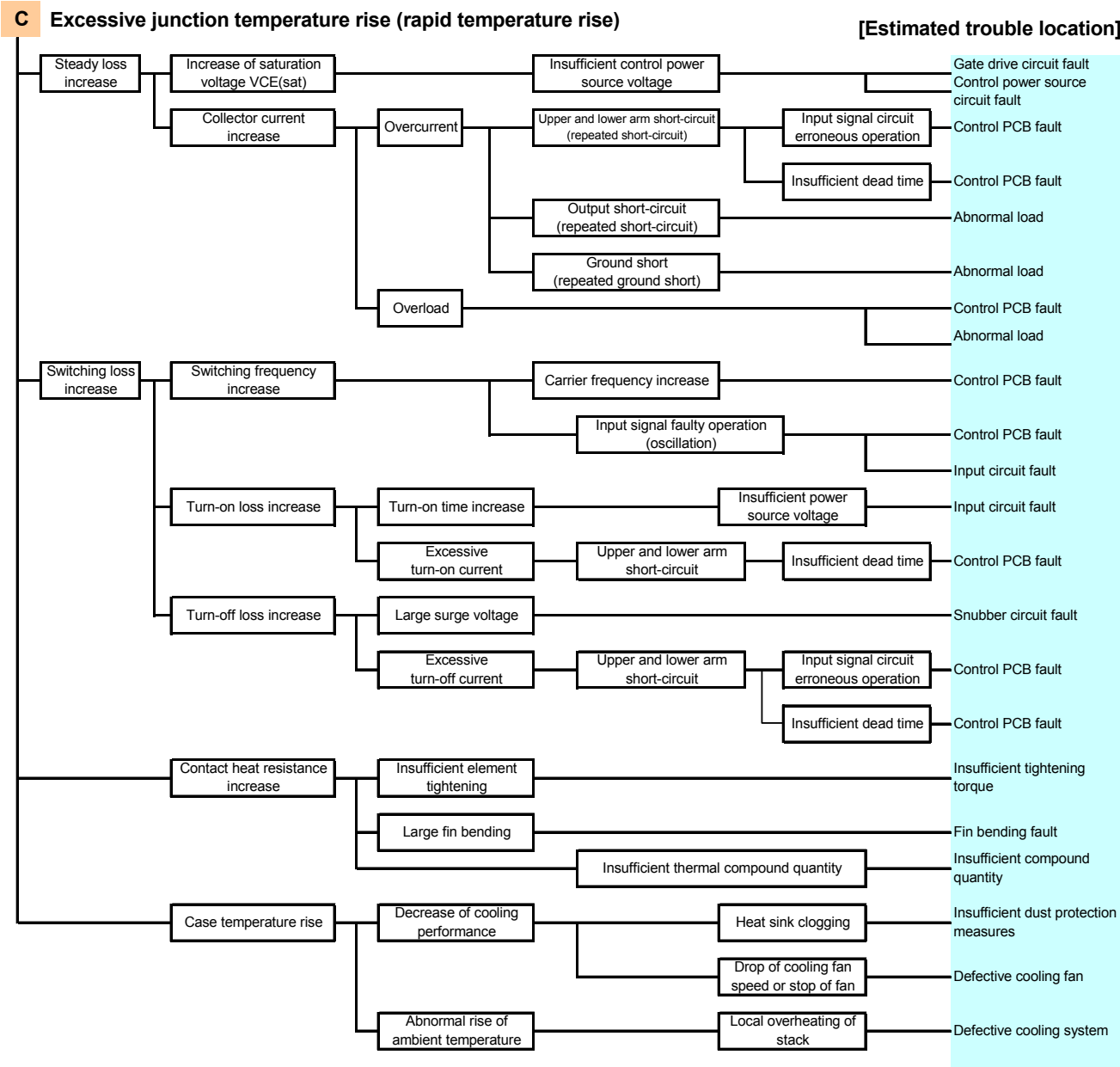

Fig. 7-1 (d) Mode C: Excessive Rise in Junction Temperature

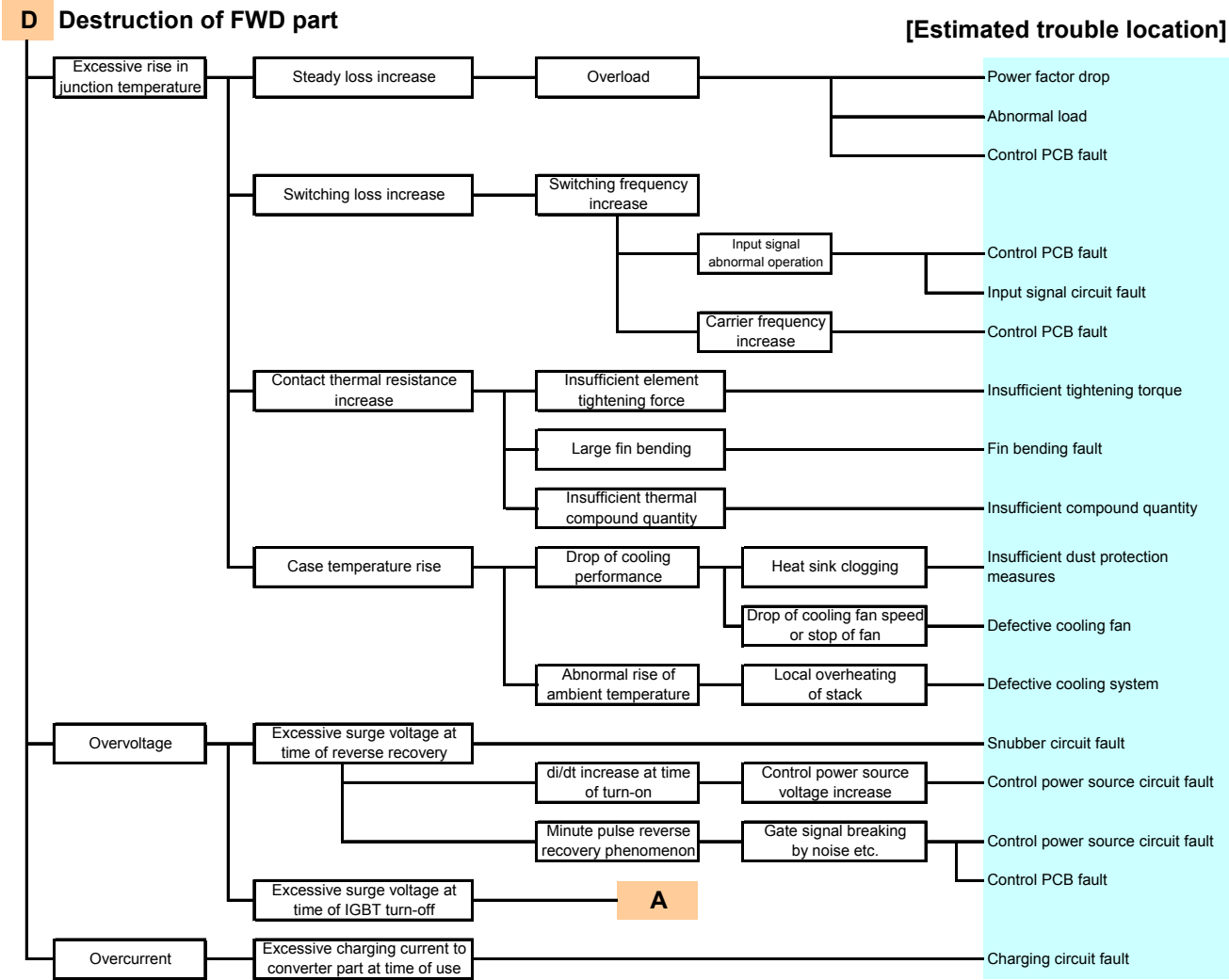

Fig. 7-1 (e) Mode D: Destruction of FWD Part

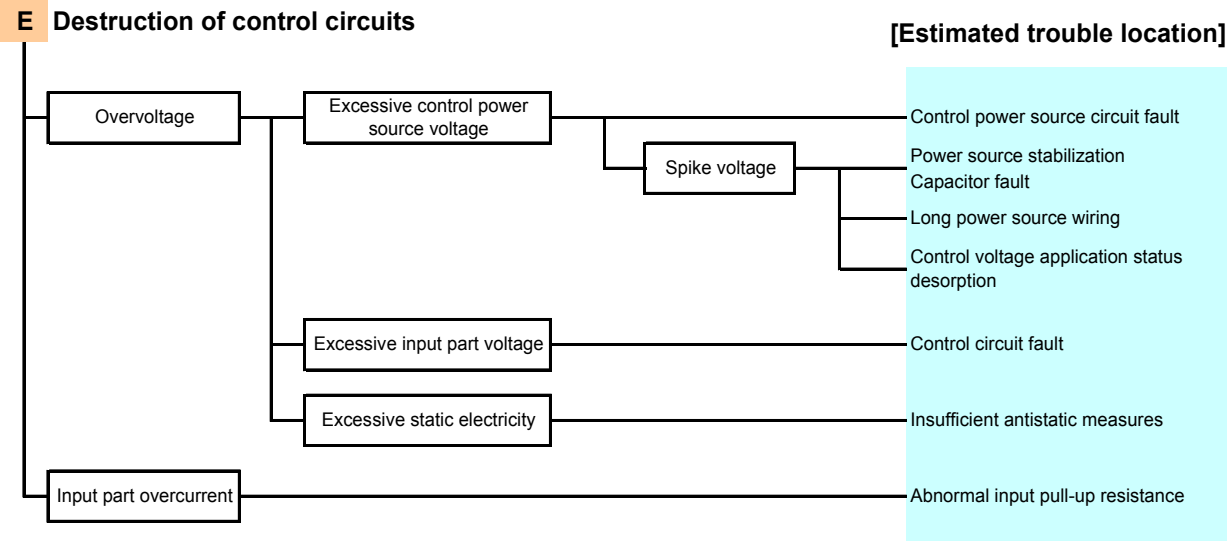

Fig. 7-1 (f) Mode E: Destruction of Control Circuit

F Damage related to reliability and product handling

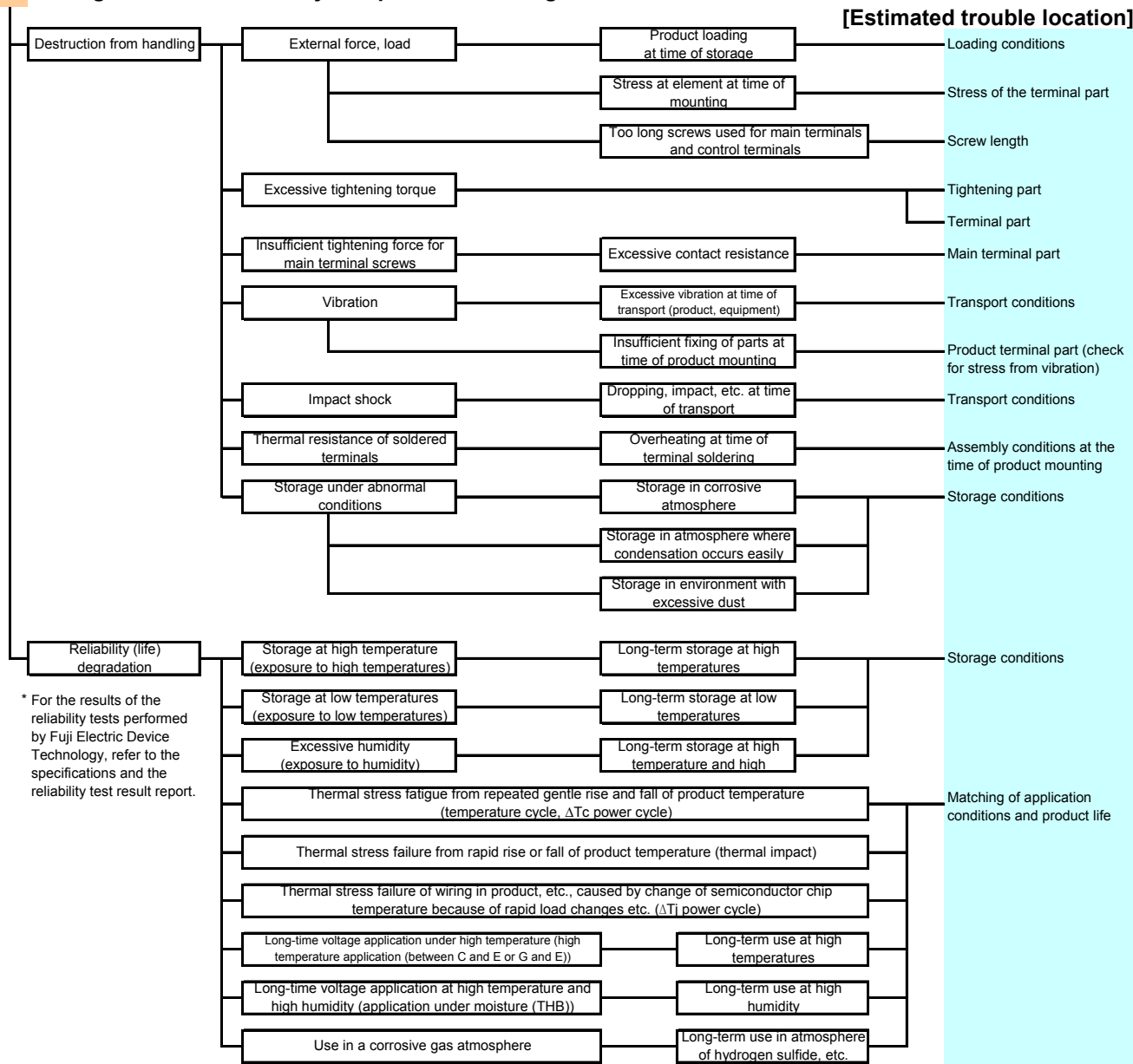

Fig. 7-1 (g) Mode F: Damage Related to Reliability and Product Handling

3 Alarm Cause Analysis Diagram

3.1 Cause analysis in the event an IPM alarm occurs

When an inverter using an IPM comes to an alarm stop, a survey must first be done to find out whether the alarm was output from the IPM or from a device control circuit (other than the IPM).

If the alarm was output by the IPM, determine the cause according to the following cause analysis diagram.

For observation of whether there is an IPM alarm or not via the alarm output voltage, the presence or absence of an alarm output can be confirmed easily by inserting a 1.5 kΩ resistor between the IPM alarm terminal and the cathode of the alarm photodiode and measuring the IPM alarm terminal voltage.

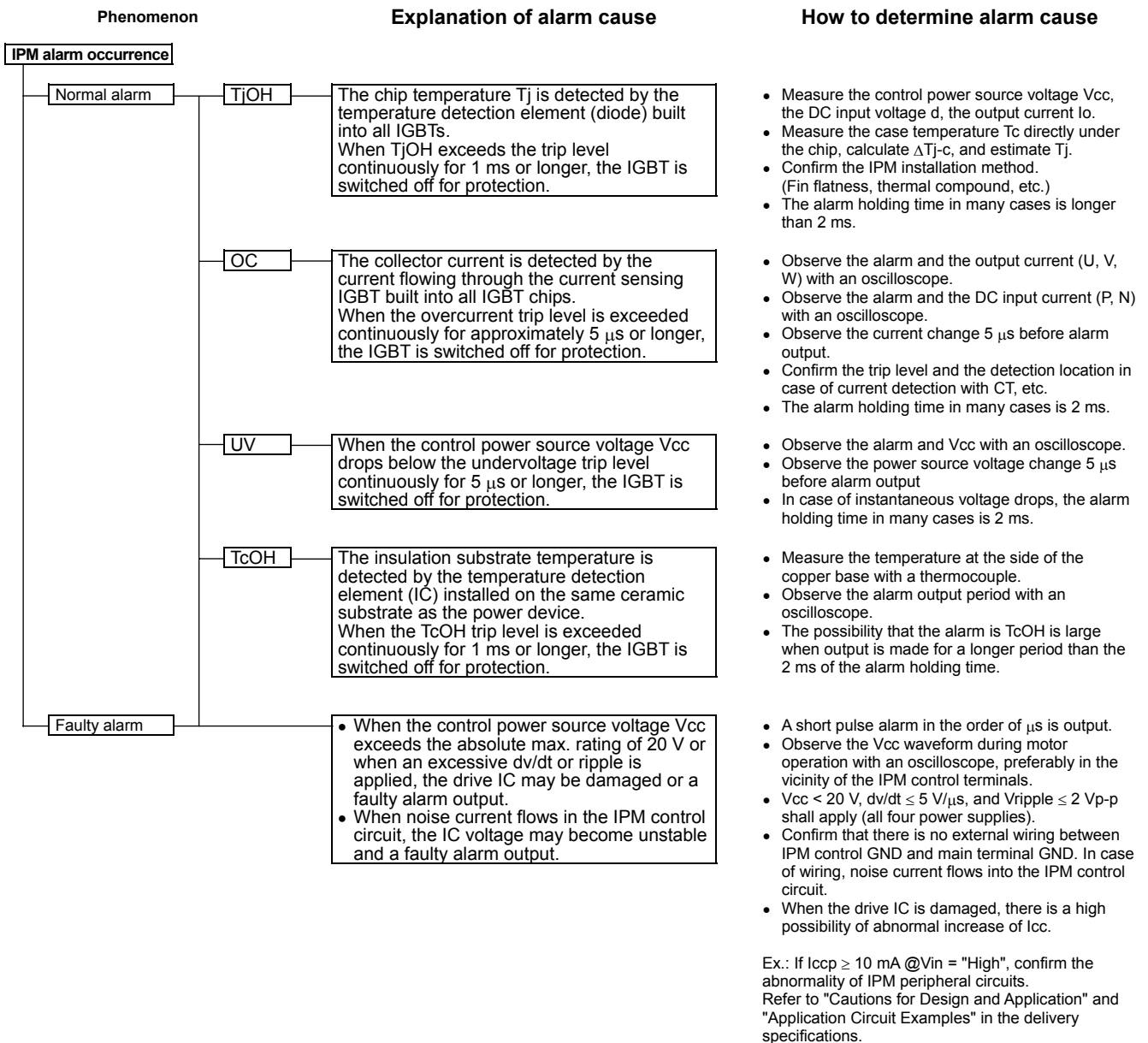

Fig. 7-2 Alarm Cause Analysis Diagram

WARNING

1. This Catalog contains the product specifications, characteristics, data, materials, and structures as of February 2004. The contents are subject to change without notice for specification changes or other reasons. When using a product listed in this Catalog, be sure to obtain the latest specifications.
2. All applications described in this Catalog exemplify the use of Fuji's products for your reference only. No right or license, either express or implied, under any patent, copyright, trade secret or other intellectual property right owned by Fuji Electric Device Technology Co., Ltd. is (or shall be deemed) granted. Fuji Electric Device Technology Co., Ltd. makes no representation or warranty, whether express or implied, relating to the infringement or alleged infringement of other's intellectual property rights which may arise from the use of the applications described herein.
3. Although Fuji Electric Device Technology Co., Ltd. is enhancing product quality and reliability, a small percentage of semiconductor products may become faulty. When using Fuji Electric semiconductor products in your equipment, you are requested to take adequate safety measures to prevent the equipment from causing a physical injury, fire, or other problem if any of the products become faulty. It is recommended to make your design fail-safe, flame retardant, and free of malfunction.
4. The products introduced in this Catalog are intended for use in the following electronic and electrical equipment which has normal reliability requirements.
 - Computers
 - OA equipment
 - Communications equipment (terminal devices)
 - Measurement equipment
 - Machine tools
 - Audiovisual equipment
 - Electrical home appliances
 - Personal equipment
 - Industrial robots etc.
5. If you need to use a product in this Catalog for equipment requiring higher reliability than normal, such as for the equipment listed below, it is imperative to contact Fuji Electric Device Technology Co., Ltd. to obtain prior approval. When using these products for such equipment, take adequate measures such as a backup system to prevent the equipment from malfunctioning even if a Fuji's product incorporated in the equipment becomes faulty.
 - Transportation equipment (mounted on cars and ships)
 - Trunk communications equipment
 - Traffic-signal control equipment
 - Gas leakage detectors with an auto-shut-off feature
 - Emergency equipment for responding to disasters and anti-burglary devices
 - Safety devices
6. Do not use products in this Catalog for the equipment requiring strict reliability such as (without limitation)
 - Space equipment
 - Aeronautic equipment
 - Nuclear control equipment
 - Submarine repeater equipment
 - Medical equipment
7. Copyright © 1996-2004 by Fuji Electric Device Technology Co., Ltd. All rights reserved.
No part of this Catalog may be reproduced in any form or by any means without the express permission of Fuji Electric Device Technology Co., Ltd.
8. If you have any question about any portion in this Catalog, ask Fuji Electric Device Technology Co., Ltd. or its sales agents before using the product.
Neither Fuji Electric Device Technology Co., Ltd. nor its agents shall be liable for any injury caused by any use of the products not in accordance with instructions set forth herein.